

P-18469-1

X2378

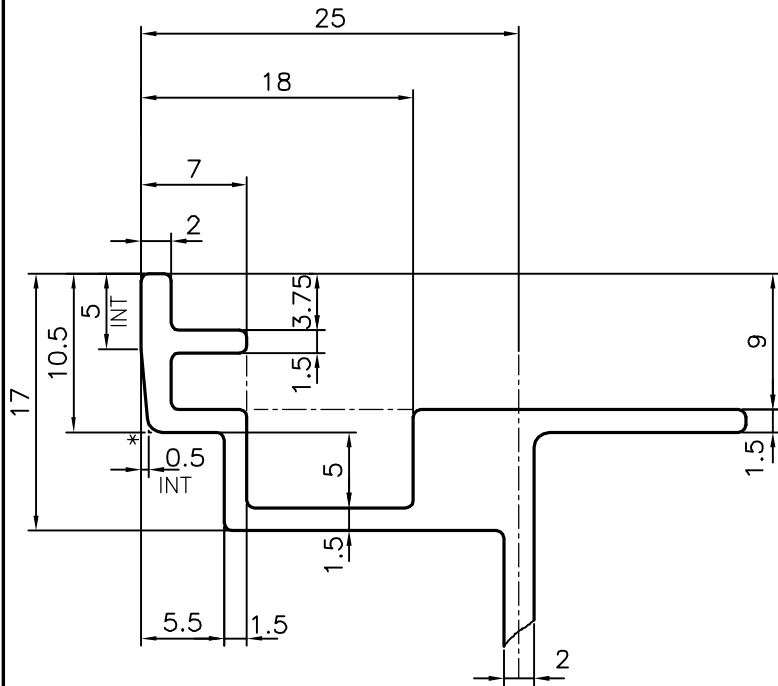

DETAIL OF "A"  
SCALE 2:1

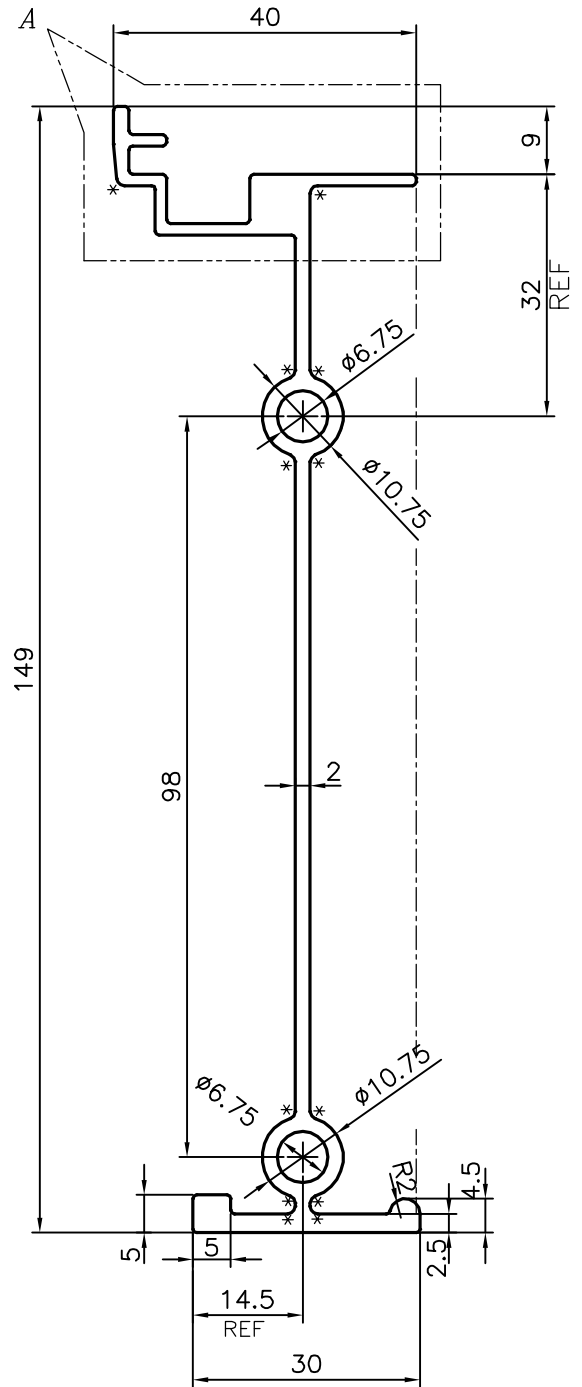

UNSPECIFIED RADIUS 0.5 mm

\* = 1.0 RADIUS (12 PLACES)

TOLERANCE CHART CD = CIRCUMSCRIBING CIRCLE

CD ≤ 100	100 < CD ≤ 200	200 < CD < 300	300 < CD < 500
UPTO 10mm - ±0.40	±0.50	±0.55	±0.60
10.0 - 25.0 - ±0.50	±0.70	±0.80	±0.90
25.0 - 50.0 - ±0.80	±0.90	±1.0	±1.20
50.0 - 100.0 - ±1.0	±1.20	±1.30	±1.60
100 - 150 - -	±1.50	±1.70	±1.80
150 - 200 - -	±1.9	±2.20	±2.40
200 - 300 - -	-	±2.50	±2.80
300 - 450 - -	-	-	±3.50



SYMBOL OF QUALITY  
AN ISO 9001 COMPANY

**JINDAL ALUMINIUM LTD.**  
BANGALORE-560073 (INDIA)

	NAME	DATE
DRAWN	J.P.KAUSHIK	21-07-2018
CHECKED		
APPROVED	B.NATARAJA	03-09-2018
SCALE		1:1
AREA mm <sup>2</sup>		566.97
PERIMETER mm.		472.908
WEIGHT kg/m		1.531
DRAWING No.	SECTION No.	
P-18469-1	-	
X2378	X2378	

1. ALL DIMENSIONS ARE IN mm.
2. ROUND OFF ALL SHARP CORNERS WITH 0.40 mm.
3. TOLERANCES WILL BE AS PER BS:EN-755-9 , UNLESS OTHERWISE SPECIFIED

PARTY'S NAME	ASA ALLOYS-MAGNA STAINLESS DIV. OF CSM. INC
PARTY'S DRAWING No.	T8000IND-SR-EX-01 REV A
ALLOY & TEMPER	6005 T6
DESCRIPTION	SIDE RAIL EXTRUSION