

P-18471-1

X2380

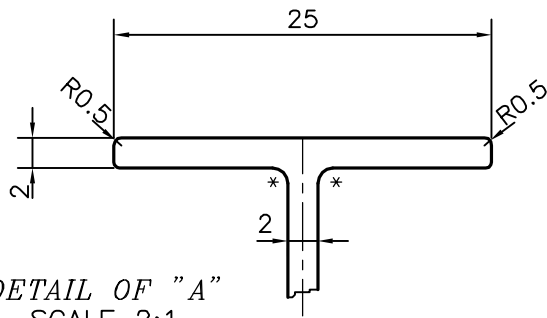

DETAIL OF "A"
SCALE 2:1

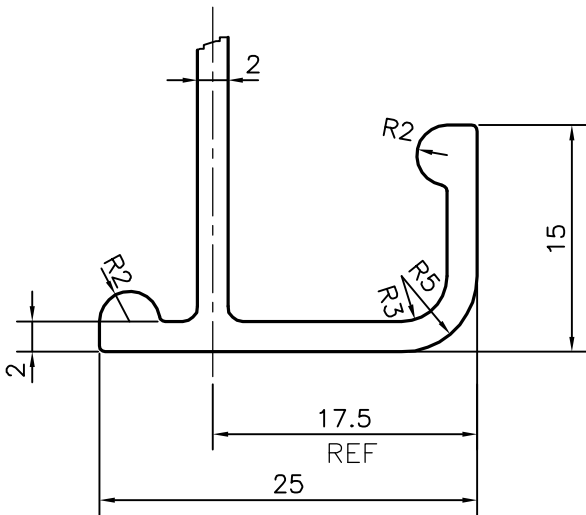

DETAIL OF "B"
SCALE 2:1

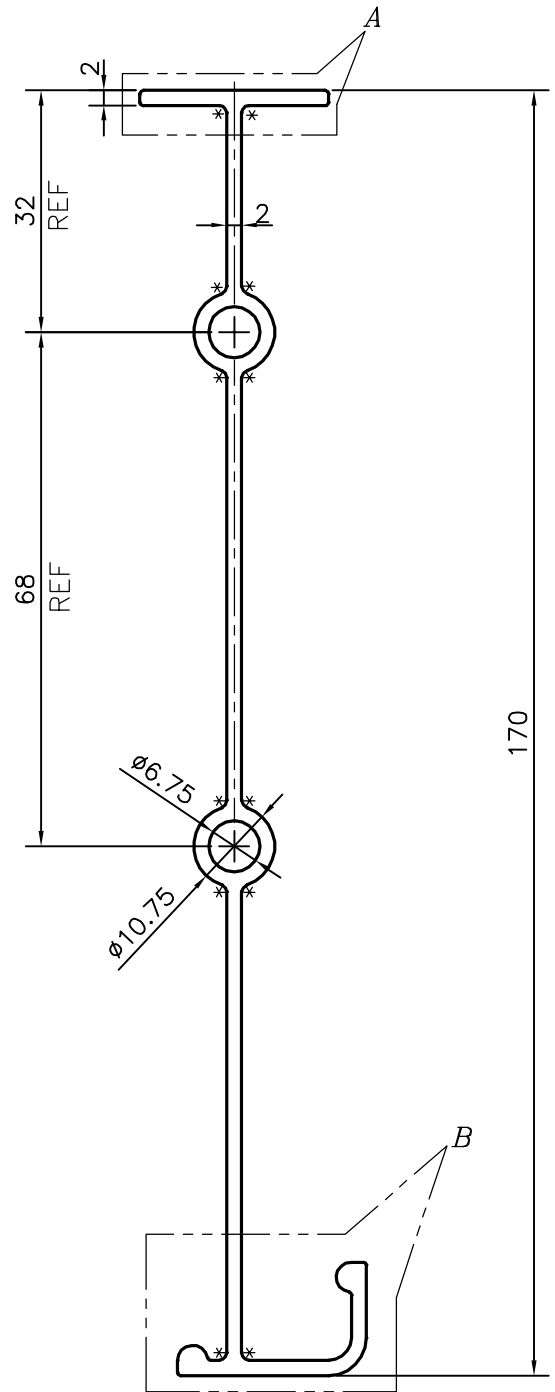

* = 1.0 RADIUS (12 PLACES)

TOLERANCE CHART CD = CIRCUMSCRIBING CIRCLE

CD ≤ 100	100 < CD ≤ 200	200 < CD < 300	300 < CD < 500
UPTO 10mm - ±0.40	±0.50	±0.55	±0.60
10.0 - 25.0 - ±0.50	±0.70	±0.80	±0.90
25.0 - 50.0 - ±0.80	±0.90	±1.0	±1.20
50.0 - 100.0 - ±1.0	±1.20	±1.30	±1.60
100 - 150 - -	±1.50	±1.70	±1.80
150 - 200 - -	±1.9	±2.20	±2.40
200 - 300 - -	-	±2.50	±2.80
300 - 450 - -	-	-	±3.50



SYMBOL OF QUALITY
AN ISO 9001 COMPANY

JINDAL ALUMINIUM LTD.
BANGALORE-560073 (INDIA)

	NAME	DATE
DRAWN	J.P.KAUSHIK	21-07-2018
CHECKED		
APPROVED	B.NATARAJA	03-09-2018
SCALE		1:1
AREA mm ²		535.87
PERIMETER mm.		475.431
WEIGHT kg/m		1.447
DRAWING No.	SECTION No.	
P-18471-1	-	
X2380	X2380	

- ALL DIMENSIONS ARE IN mm.
- ROUND OFF ALL SHARP CORNERS WITH 0.40 mm.
- TOLERANCES WILL BE AS PER BS:EN-755-9, UNLESS OTHERWISE SPECIFIED

PARTY'S NAME	ASA ALLOYS-MAGNA STAINLESS DIV. OF CSM. INC
PARTY'S DRAWING No.	T8000IND-RIB-EX-00
ALLOY & TEMPER	6005 T6
DESCRIPTION	T8000 IND RIB EXTRUSION