

P-18640

X2390

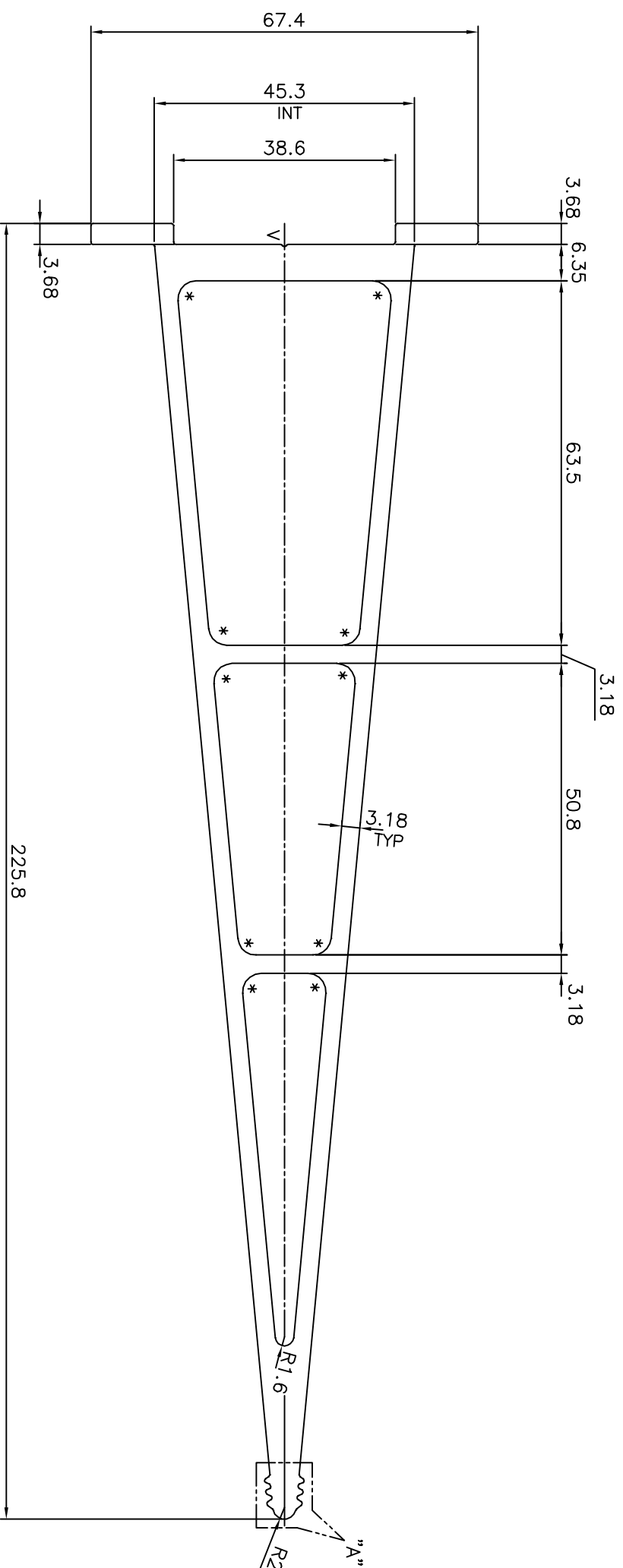

TOLERANCE CHART CD = CIRCUMSCRIBING CIRCLE

CD ≤ 100	100 < CD ≤ 200	200 < CD ≤ 300	300 < CD ≤ 500
UP TO 10mm - ±0.25	±0.30	±0.35	±0.40
10.0 - 25.0 - ±0.30	±0.40	±0.50	±0.60
25.0 - 50.0 - ±0.50	±0.60	±0.80	±0.90
50.0 - 100.0 - ±0.70	±0.90	±1.10	±1.30
100 - 150 - -	±1.10	±1.30	±1.50
150 - 200 - -	±1.30	±1.50	±1.80
200 - 300 - -	±1.50	±1.70	±2.10
300 - 450 - -	-	-	±2.80

V = V GROOVE 0.4x90° (ONE PLACE)  
 \* = RADIUS 3.18 (10 PLACES)

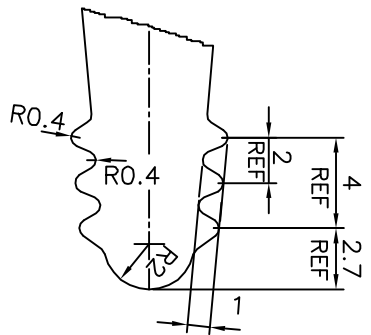

DETAIL "A"  
 SCALE 3:1

 <p>SYMBOL OF QUALITY          AN ISO 9001 COMPANY</p>		<p><b>JINDAL ALUMINIUM LTD.</b>          BANGALORE-560073 (INDIA)</p>	
<p>1. ALL DIMENSIONS ARE IN mm.          2. ROUND OFF ALL SHARP CORNERS WITH 0.40 mm.          3. TOLERANCES WILL BE AS PER BS:EN-755-9 UNLESS OTHERWISE SPECIFIED</p>		<p>SCALE 1:1          AREA mm<sup>2</sup> 1929.262          PERIMETER mm. 557.273          WEIGHT kg/m 5.209</p>	
PARTY'S NAME	LUCID MANAGEMENT GROUP, CANADA	DRAWN	J.P.KAUSHIK
PARTY'S DRAWING No.	AS PER SAMPLE	CHECKED	
ALLOY & TEMPER	6063 T6	APPROVED	B.NATARAJA
DESCRIPTION	SUN SHADE	SCALE	25-09-2018
		DRAWING No.	SECTION No.
		P-18640	-
		X2390	X2390