

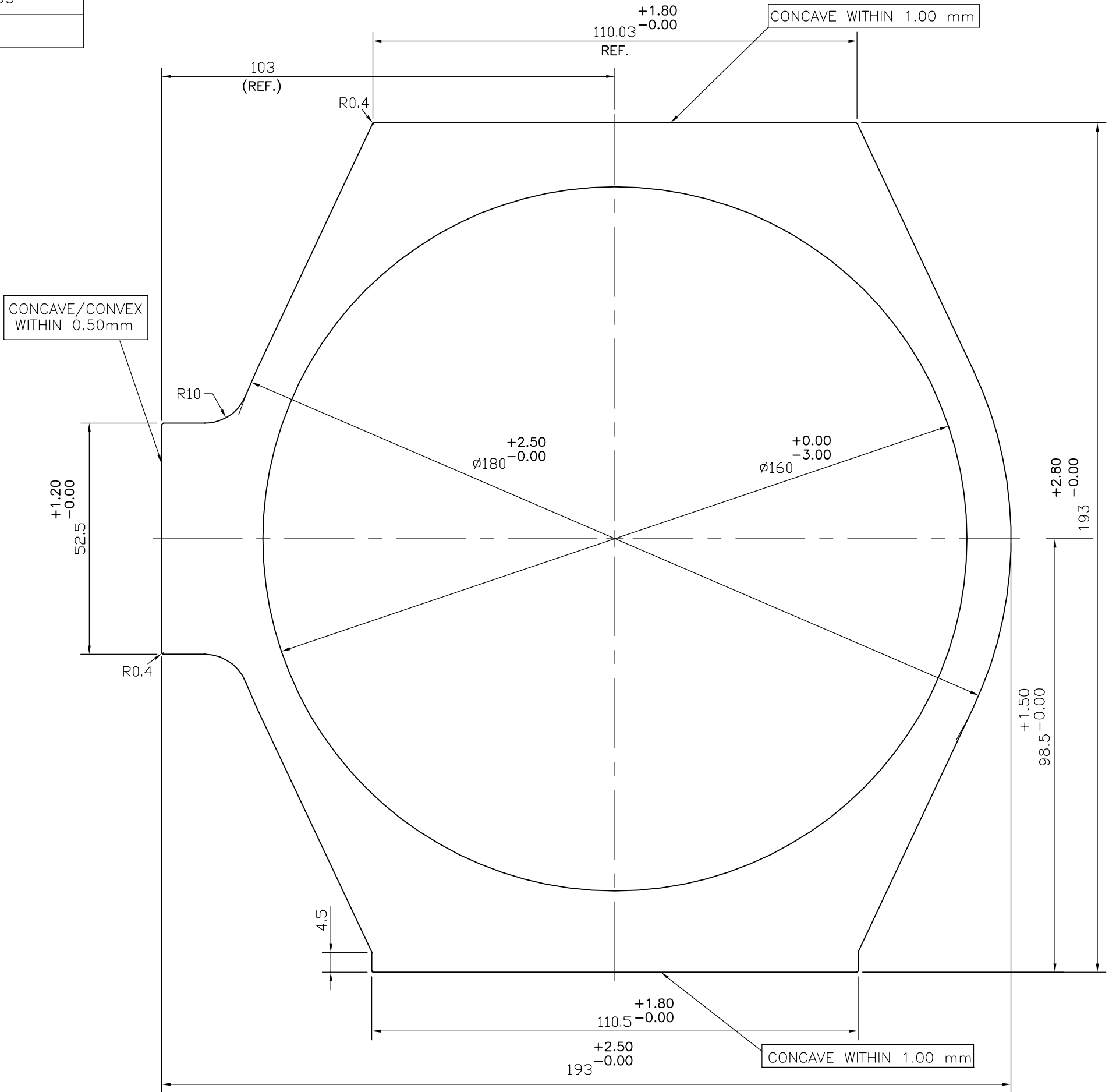

P-18728-3

X2409



TOLERANCES ON OVERALL DIMENSIONS OF HOLLOW SECTIONS				
UPTO 20.0mm - ±0.30	UPTO 80.0mm - ±0.70	UPTO 180.0mm - ±1.27	1. STRAIGHTNESS=1.7mm/M 2. TWIST=1.7mm/M 3. ANGULARITY= ±2° 4. FLATNESS =0.006xWIDTH	
UPTO 30.0mm - ±0.38	UPTO 100.0mm - ±0.80	UPTO 200.0mm - ±1.40		
UPTO 40.0mm - ±0.45	UPTO 120.0mm - ±0.90	UPTO 225.0mm - ±1.52		
UPTO 50.0mm - ±0.52	UPTO 140.0mm - ±1.00			
UPTO 60.0mm - ±0.60	UPTO 160.0mm - ±1.14			
 SYMBOL OF QUALITY AN ISO 9001 COMPANY	<b>JINDAL ALUMINIUM LTD.</b> BANGALORE-560073 (INDIA)		NAME	DATE
			DRAWN	DARPAN
1. ALL DIMENSIONS ARE IN mm. 2. ROUND OFF ALL SHARP CORNERS WITH 0.40 mm. 3. TOLERANCES WILL BE AS PER IS:6477-1983 UNLESS OTHERWISE SPECIFIED			CHECKED	
			APPROVED	B.NATARAJA
PARTY'S NAME DEETECH INDUSTRIES, PUNE			SCALE	1:1
			AREA mm <sup>2</sup>	9801.825
PARTY'S DRAWING No. 7010980			PERIMETER mm.	663.615
			WEIGHT kg/m	26.465
ALLOY & TEMPER AlMgSi0.5 F22			DRAWING No.	SECTION No.
			P-18728-3	-
DESCRIPTION PUMP BODY SECTION			X2409	X2409