

P-18805

X2422

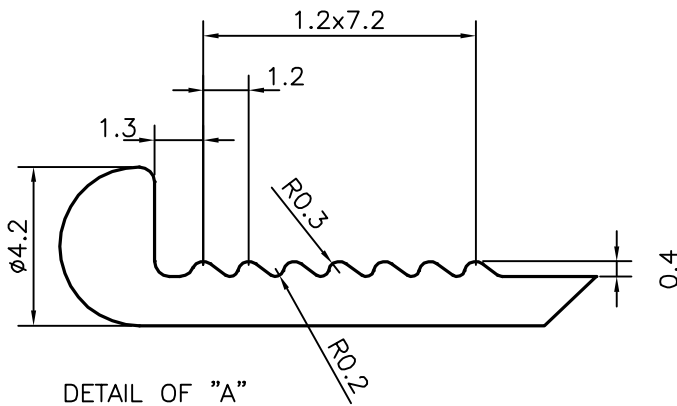

DETAIL OF "A"
SCALE 5:1

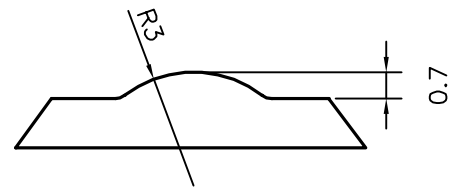

DETAIL OF "B"
SCALE 5:1

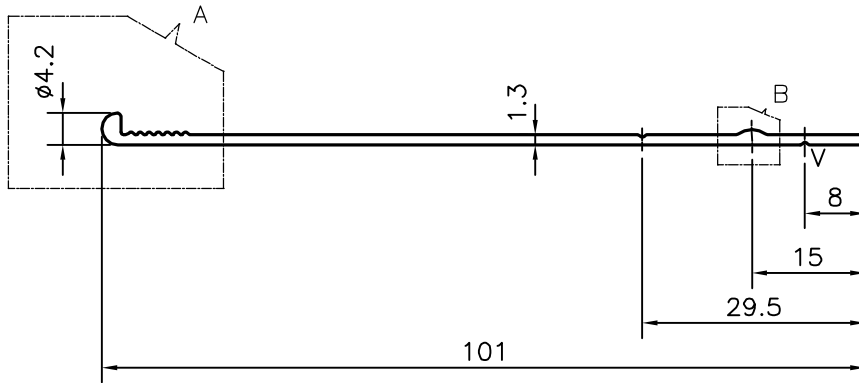

V = V GROOVE 0.3X90° (2 PLACES)



SYMBOL OF QUALITY
AN ISO 9001 COMPANY

JINDAL ALUMINIUM LTD.
BANGALORE-560073 (INDIA)

	NAME	DATE
DRAWN	DARPAN	12-11-2018
CHECKED		
APPROVED	B,NATARAJA	6-11-2018
SCALE		1:1
AREA mm ²		139.919
PERIMETER mm.		210.802
WEIGHT kg/m		0.378
DRAWING No.	SECTION No.	
P-18805	-	
X2422	X2422	

1. ALL DIMENSIONS ARE IN mm.
2. ROUND OFF ALL SHARP CORNERS WITH 0.40 mm.
3. TOLERANCES WILL BE AS PER IS:3965-1981 , UNLESS OTHERWISE SPECIFIED

PARTY'S NAME	GENERAL CATEGORY, MUMBAI MARKET
PARTY'S DRAWING No.	AS PER SAMPLE
ALLOY & TEMPER	6063 T6
DESCRIPTION	MISC, SECTION