

P-9862

X2455

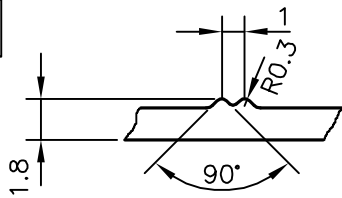

DETAIL "A"  
SCALE 3:1

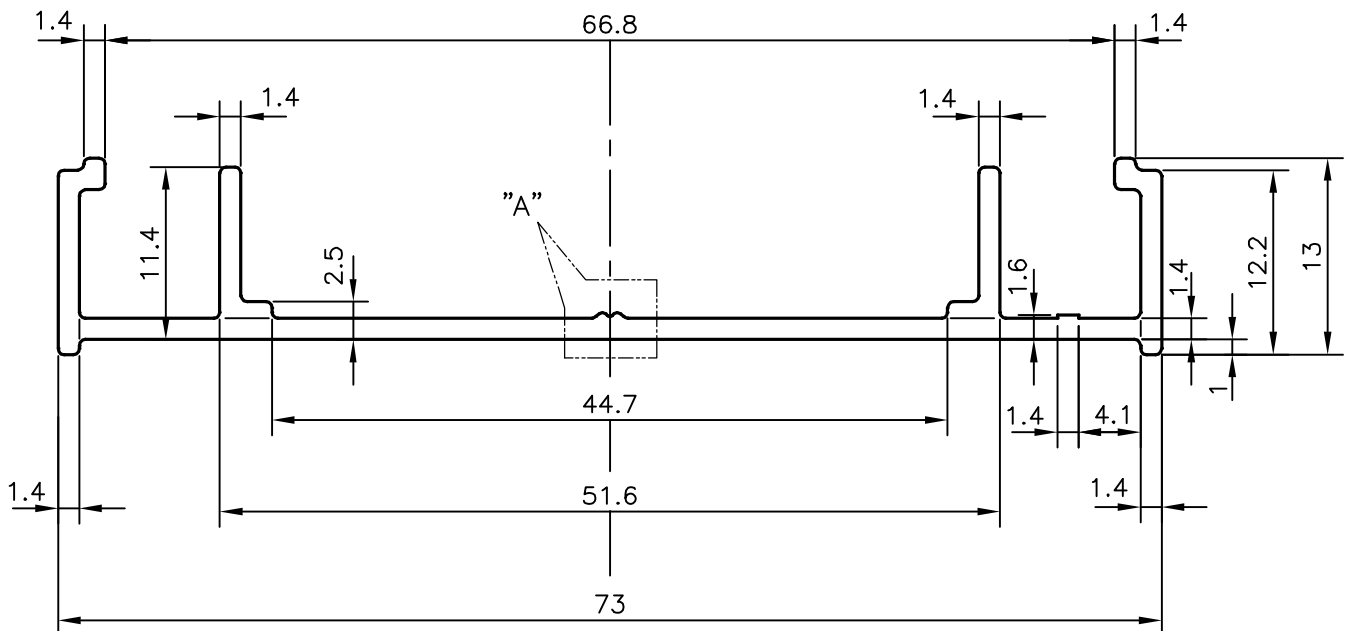
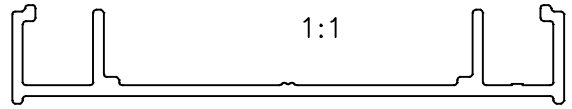

SYMBOL OF QUALITY  
AN ISO 9001 COMPANY

**JINDAL ALUMINIUM LTD.**  
BANGALORE-560073 (INDIA)

	NAME	DATE
DRAWN	J.P.KAUSHIK	09-03-2010
CHECKED		
APPROVED	J.N.RAI	13-12-2018

1. ALL DIMENSIONS ARE IN mm.
2. ROUND OFF ALL SHARP CORNERS WITH 0.40 mm.
3. TOLERANCES WILL BE AS PER BS:EN-755, UNLESS OTHERWISE SPECIFIED

SCALE	2:1
AREA mm <sup>2</sup>	172.279
PERIMETER mm.	237.377
WEIGHT kg/m	0.465

PARTY'S NAME SLV, 30 RUE CLAUDE CHAPPE

PARTY'S DRAWING No. AS PER SAMPLE

ALLOY & TEMPER 6063 T6

DESCRIPTION MISC. SECTION

DRAWING No.	SECTION No.
P-9862	-
X2455	X2455