

P-19227-1

X2491

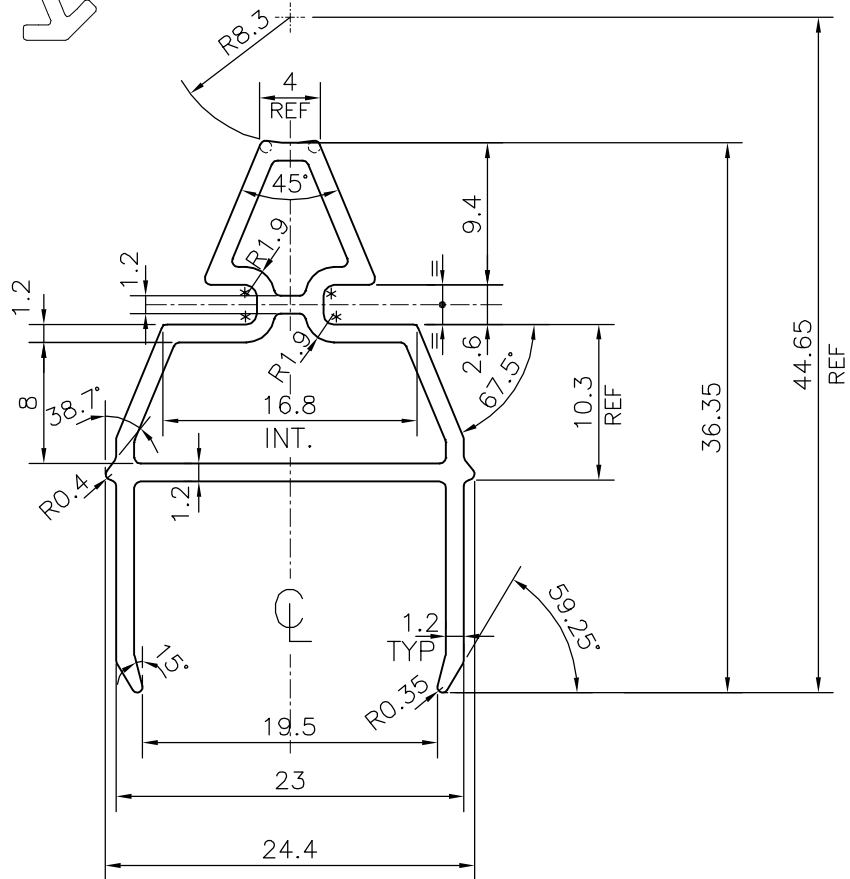
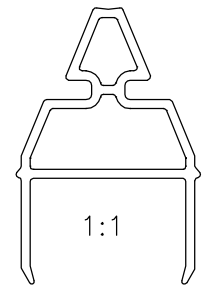
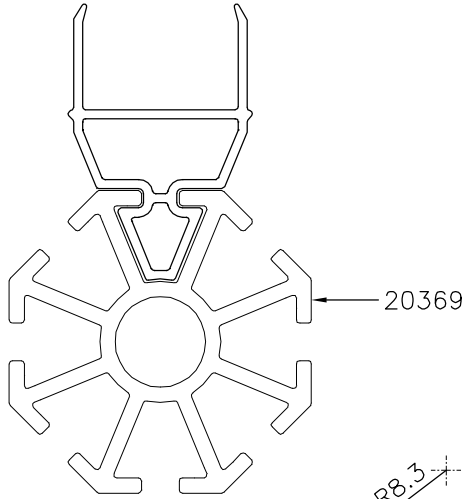

ISSUE-2

SIZE & SHAPE CHANGED

* = 0.7 RADIUS (4 PLACES)



SYMBOL OF QUALITY
AN ISO 9001 COMPANY

JINDAL ALUMINIUM LTD.
BANGALORE-560073 (INDIA)

	NAME	DATE
DRAWN	J.P.KAUSHIK	23-07-2019
CHECKED		
APPROVED	B.NATARAJA	02-08-2019
SCALE		2:1
AREA mm ²		141.141
PERIMETER mm.		147.766
WEIGHT kg/m		0.381
DRAWING No.	SECTION No.	
P-19227-1	-	
X2491	X2491 (ISSUE-2)	

1. ALL DIMENSIONS ARE IN mm.
2. ROUND OFF ALL SHARP CORNERS WITH 0.40 mm.
3. TOLERANCES WILL BE AS PER IS:6477-1983 , UNLESS OTHERWISE SPECIFIED

PARTY'S NAME	FAMELINE ARCHITECTURAL PRODUCTS, BANGALORE
PARTY'S DRAWING No.	AS PER DRAWING
ALLOY & TEMPER	6063 T6
DESCRIPTION	MISC. SECTION