

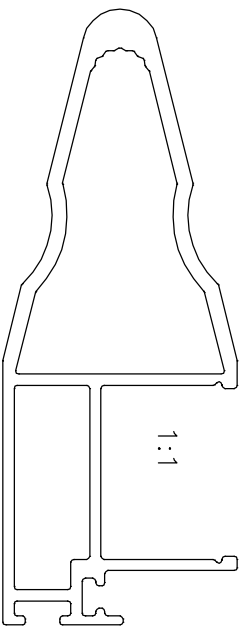

P-19408-1

X2530

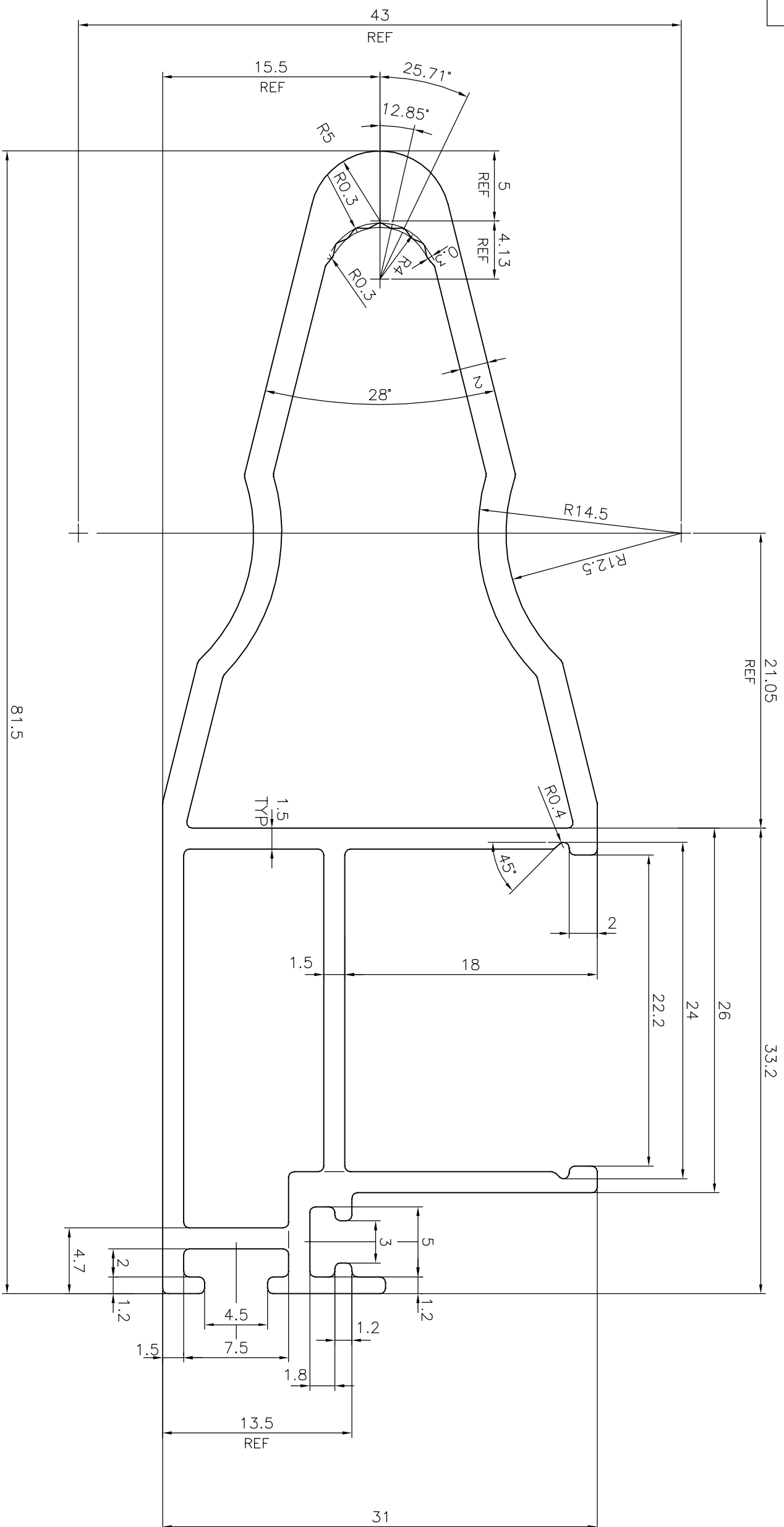

1:1

 <p>SYMBOL OF QUALITY AN ISO 9001 COMPANY</p>		<p><b>JINDAL ALUMINIUM LTD.</b> BANGALORE-560073 (INDIA)</p>		<p>1. ALL DIMENSIONS ARE IN mm. 2. ROUND OFF ALL SHARP CORNERS WITH 0.40 mm. 3. TOLERANCES WILL BE AS PER IS:6477-1983 UNLESS OTHERWISE SPECIFIED</p>	<p>NAME</p> <p>J.P.KAUSHIK</p>	<p>DATE</p> <p>11-05-2019</p>
				<p>PARTY'S NAME</p> <p>MAHARASHTRA ALUMINIUM CENTRE, BHIWANDI</p>	<p>SCALE</p> <p>3:1</p>	<p>APPROVED</p> <p>B.MATARAMA</p>
<p>PARTY'S DRAWING No.</p> <p>AS PER SAMPLE</p>	<p>MAHARASHTRA ALUMINIUM CENTRE, BHIWANDI</p>	<p>AREA mm<sup>2</sup></p> <p>426.431</p>	<p>PERIMETER mm.</p> <p>264.84</p>	<p>WEIGHT kg/m</p> <p>1.151</p>	<p>DRAWING No.</p> <p>P-19408-1</p>	<p>SECTION No.</p> <p>-</p>
<p>ALLOY &amp; TEMPER</p> <p>6063 T6</p>	<p>MAHARASHTRA ALUMINIUM CENTRE, BHIWANDI</p>	<p>PERIMETER mm.</p> <p>264.84</p>	<p>WEIGHT kg/m</p> <p>1.151</p>	<p>DRAWING No.</p> <p>P-19408-1</p>	<p>SECTION No.</p> <p>-</p>	<p>DESCRIPTION</p> <p>WINDOW SECTION</p>