

P-19861

X2564

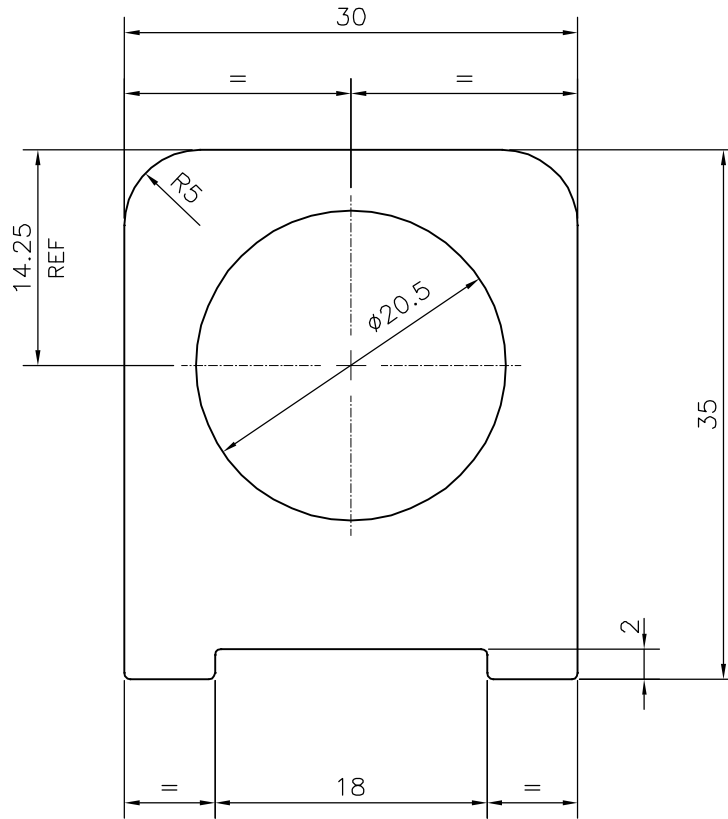
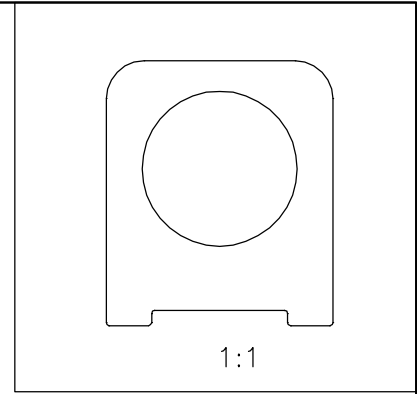

SYMBOL OF QUALITY
AN ISO 9001 COMPANY

JINDAL ALUMINIUM LTD.
BANGALORE-560073 (INDIA)

	NAME	DATE
DRAWN	J.P.KAUSHIK	17-07-2019
CHECKED		
APPROVED	B.NATARAJA	30-07-2019

1. ALL DIMENSIONS ARE IN mm.
2. ROUND OFF ALL SHARP CORNERS WITH 0.40 mm.
3. TOLERANCES WILL BE AS PER BS:EN-755-9 , UNLESS OTHERWISE SPECIFIED

SCALE	2:1
AREA mm ²	673.138
PERIMETER mm.	128.678
WEIGHT kg/m	1.817

PARTY'S NAME	HERMANN MOHN GMBH & CO. KG, GERMANY
PARTY'S DRAWING No.	HU1535-1-2 REV. B
ALLOY & TEMPER	6063 T6 & 6061 T6
DESCRIPTION	MISC. SECTION

DRAWING No.	SECTION No.
P-19861	-
X2564	X2564