

P-20236-1

X2598

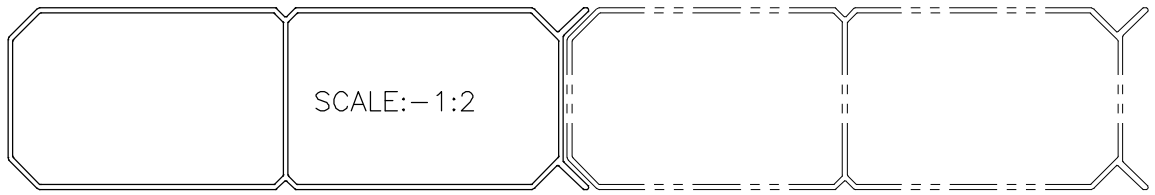

SCALE:- 1:2

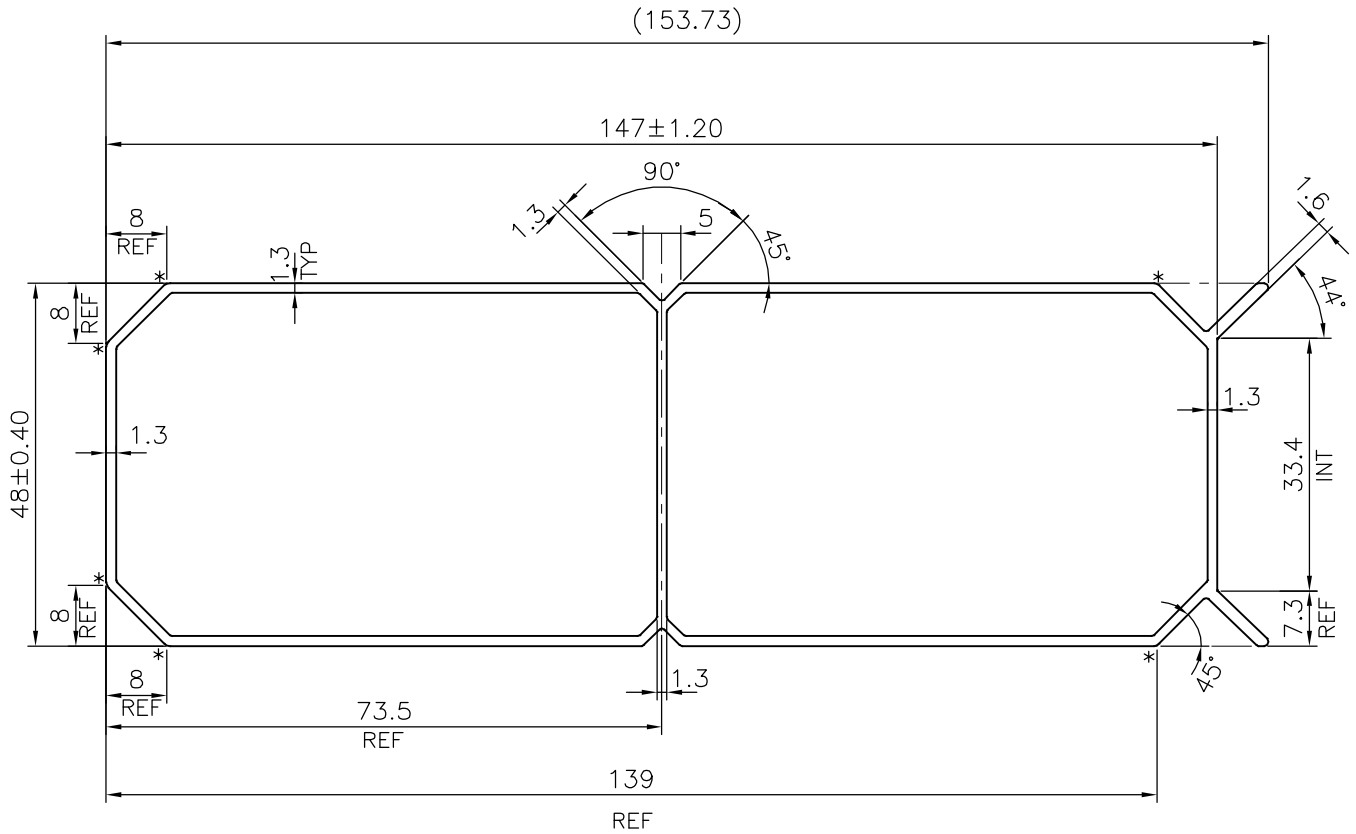

TOLERANCE CHART CD = CIRCUMSCRIBING CIRCLE

	CD ≤ 100	100 < CD ≤ 200	200 < CD ≤ 300	300 < CD ≤ 500
UPTO 10mm	- ±0.25	±0.30	±0.35	±0.40
10.0 - 25.0	- ±0.30	±0.40	±0.50	±0.60
25.0 - 50.0	- ±0.50	±0.60	±0.80	±0.90
50.0 - 100.0	- ±0.70	±0.90	±1.10	±1.30
100 - 150	- -	±1.10	±1.30	±1.50
150 - 200	- -	±1.3	±1.50	±1.80
200 - 300	- -	-	±1.70	±2.10
300 - 450	- -	-	-	±2.80

* = 1.0 RADIUS (6 PLACES)



SYMBOL OF QUALITY
AN ISO 9001 COMPANY

JINDAL ALUMINIUM LTD.
BANGALORE-560073 (INDIA)

	NAME	DATE
DRAWN	J.P.KAUSHIK	16-10-2019
CHECKED		
APPROVED	B.NATARAJA	18-10-2019

1. ALL DIMENSIONS ARE IN mm.
2. ROUND OFF ALL SHARP CORNERS WITH 0.40 mm.
3. TOLERANCES WILL BE AS PER BS:EN-755-9 , UNLESS OTHERWISE SPECIFIED

SCALE	1:1
AREA mm ²	567.058
PERIMETER mm.	413.012
WEIGHT kg/m	1.531

PARTY'S NAME	AFFORDABLE BALUSTRADES, AUSTRALIA
PARTY'S DRAWING No.	1316B REV.-2/3
ALLOY & TEMPER	6063 T6
DESCRIPTION	MISC. TUBE

DRAWING No.	SECTION No.
P-20236-1	-
X2598	X2598