

P-20601

X2618

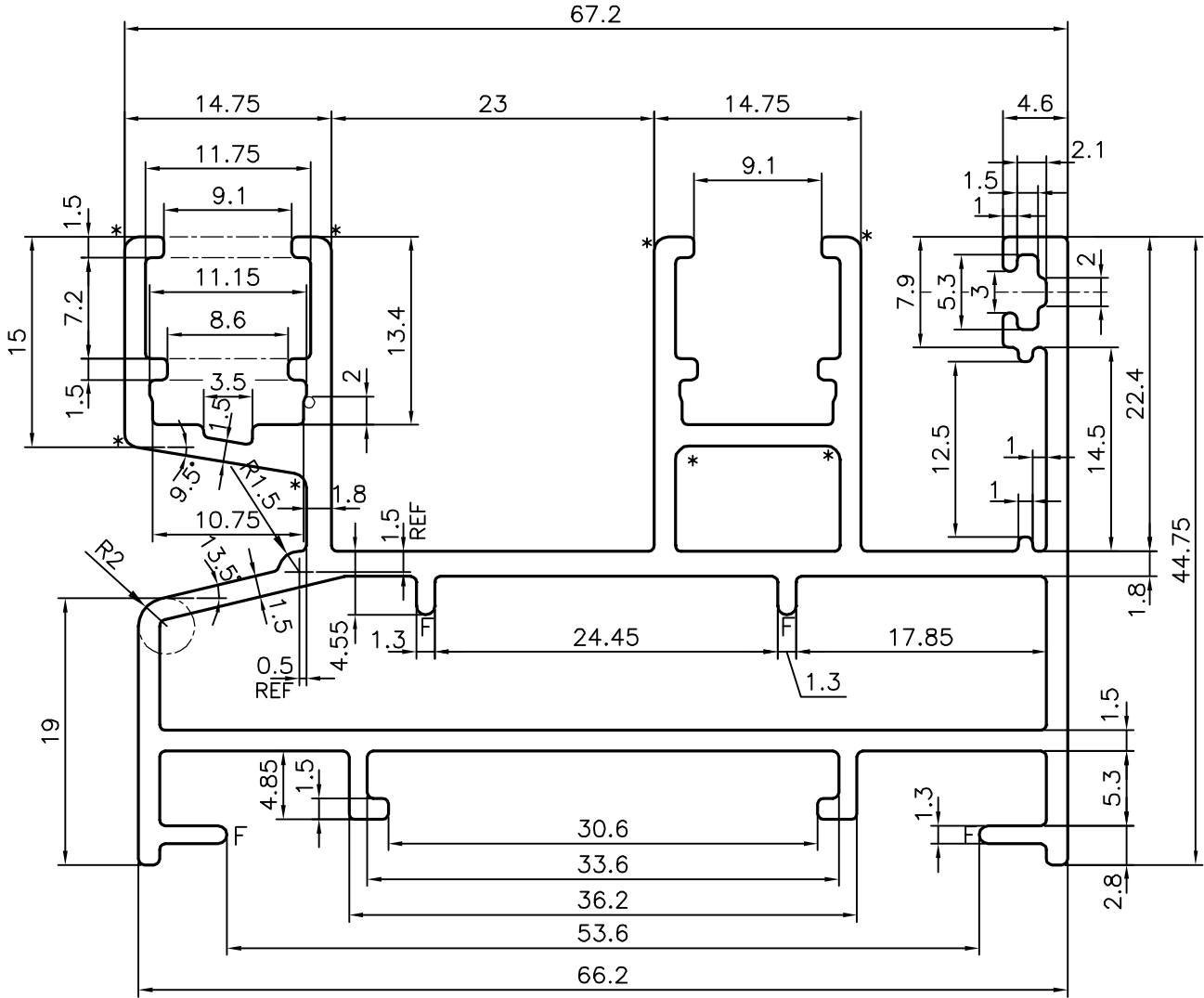

* = 1.0 RADIUS (8 PLACES)
 F = FULL RADIUS (4 PLACES)

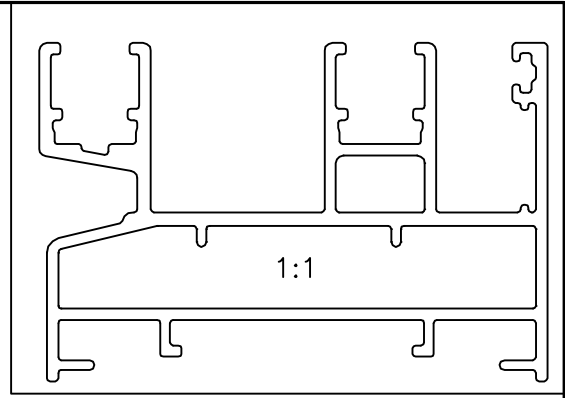

SYMBOL OF QUALITY
 AN ISO 9001 COMPANY

JINDAL ALUMINIUM LTD.
 BANGALORE-560073 (INDIA)

	NAME	DATE
DRAWN	J.P.KAUSHIK	09-01-2020
CHECKED		
APPROVED	B.NATARAJA	24-01-2020

- ALL DIMENSIONS ARE IN mm.
- ROUND OFF ALL SHARP CORNERS WITH 0.40 mm.
- TOLERANCES WILL BE AS PER IS:6477-1983 UNLESS OTHERWISE SPECIFIED

SCALE	2:1
AREA mm ²	546.425
PERIMETER mm.	471.814
WEIGHT kg/m	1.475

PARTY'S NAME	HARI ALUMINIUM, AHMEDABAD
PARTY'S DRAWING No.	AS PER DRAWING
ALLOY & TEMPER	6063 T6
DESCRIPTION	WINDOW SECTION

DRAWING No.	SECTION No.
P-20601	
X2618	X2618