

P-14063-1

X2631

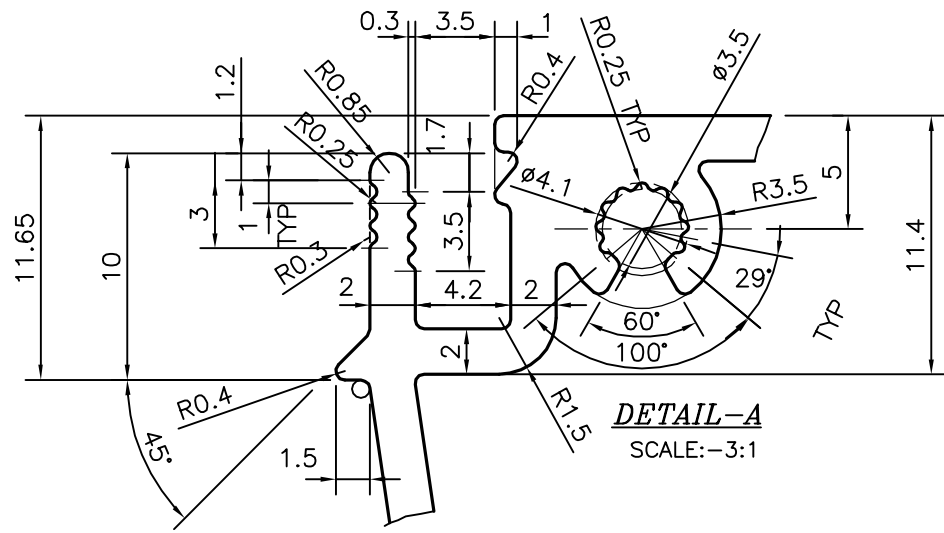

DETAIL-A
SCALE: -3:1

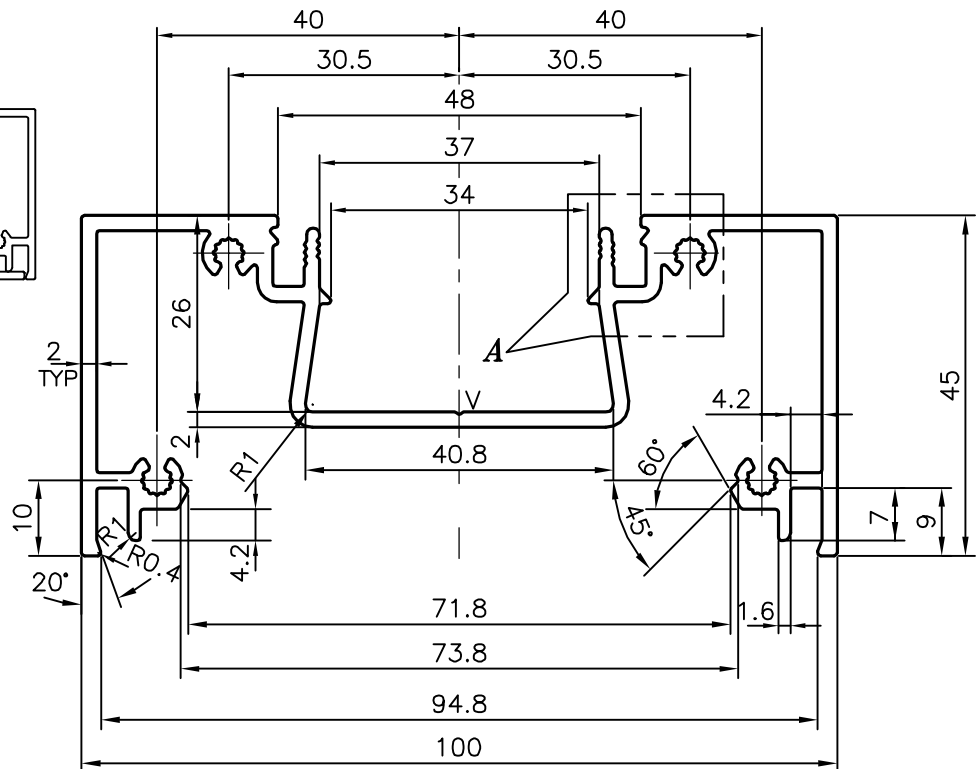
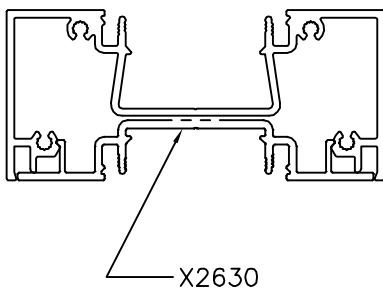

TOLERANCE CHART CD = CIRCUMSCRIBING CIRCLE

CD ≤ 100	100 < CD ≤ 200	200 < CD ≤ 300	300 < CD ≤ 500
UPTO 10mm - ±0.25	±0.30	±0.35	±0.40
10.0 - 25.0 - ±0.30	±0.40	±0.50	±0.60
25.0 - 50.0 - ±0.50	±0.60	±0.80	±0.90
50.0 - 100.0 - ±0.70	±0.90	±1.10	±1.30
100 - 150 - -	±1.10	±1.30	±1.50
150 - 200 - -	±1.3	±1.50	±1.80
200 - 300 - -	-	±1.70	±2.10
300 - 450 - -	-	-	±2.80

V = VEE GROOVE 0.3x90°xR0.3 (3 PLACES)



SYMBOL OF QUALITY
AN ISO 9001 COMPANY

JINDAL ALUMINIUM LTD.
BANGALORE-560073 (INDIA)

	NAME	DATE
DRAWN	J.P.KAUSHIK	26-10-2019
CHECKED		
APPROVED	B.NATARAJA	27-02-2020
SCALE		1:1
AREA mm ²		655.992
PERIMETER mm.		644.754
WEIGHT kg/m		1.771
DRAWING No.	SECTION No.	
P-14063-1	-	
X2631	X2631	

- ALL DIMENSIONS ARE IN mm.
- ROUND OFF ALL SHARP CORNERS WITH 0.40 mm.
- TOLERANCES WILL BE AS PER BS:EN-755-9 UNLESS OTHERWISE SPECIFIED

PARTY'S NAME	PD ALUMINIUM LTD., UK
PARTY'S DRAWING No.	AS PER SAMPLE (PDG-1)
ALLOY & TEMPER	6063 T6
DESCRIPTION	MISC. SECTION