

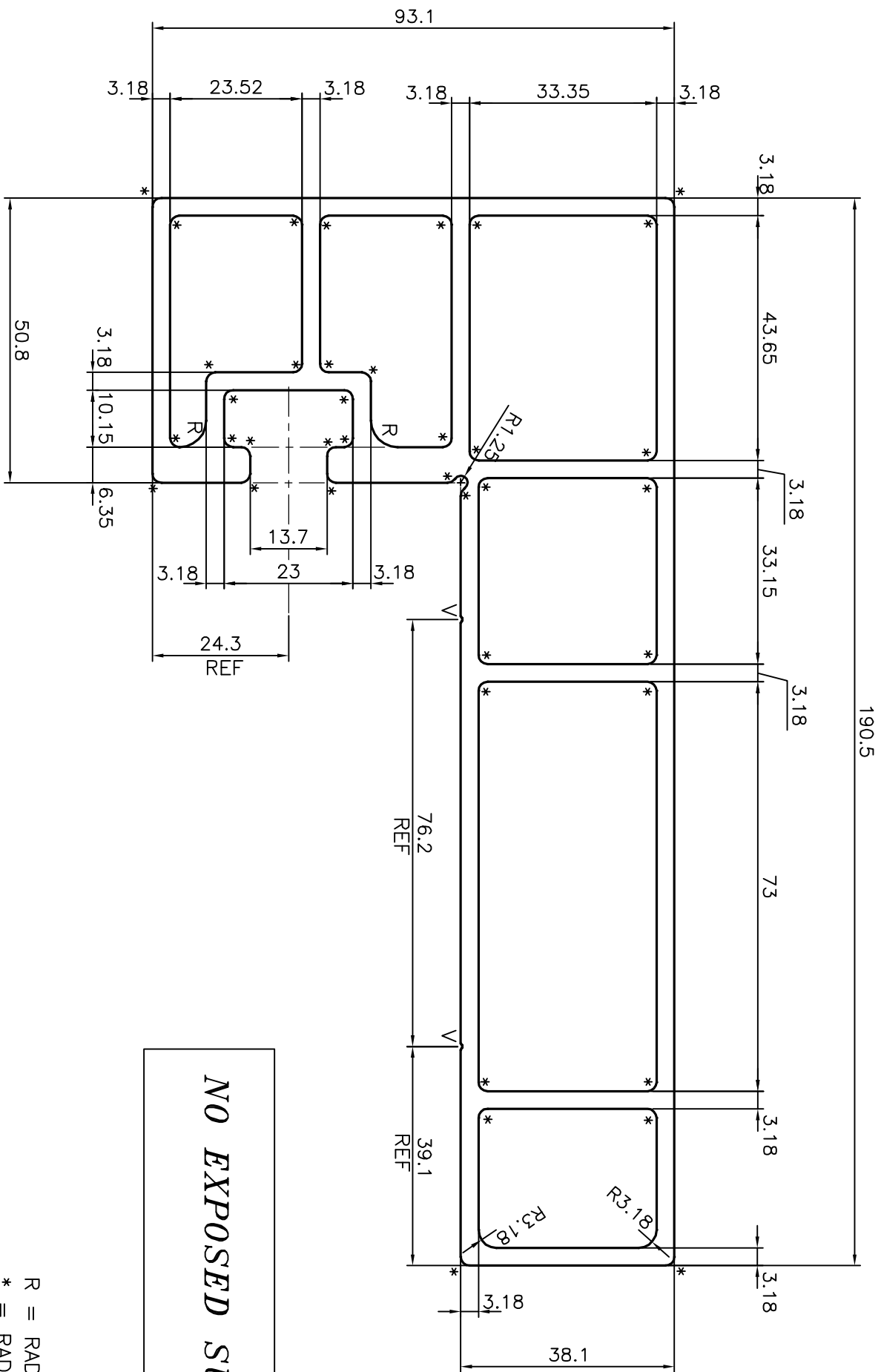

P-20915

X2645



NO EXPOSED SURFACE

R = RADIUS 4.75 (2 PLACES)
 * = RADIUS 1.6 (39 PLACES)
 V = V GROOVE 0.30x90° (2 PLACES)

 SYMBOL OF QUALITY AN ISO 9001 COMPANY		JINDAL ALUMINIUM LTD. BANGALORE-560073 (INDIA)		DRAWN J.P.KAUSHIK 02-04-2020	NAME DATE
1. ALL DIMENSIONS ARE IN mm. 2. ROUND OFF ALL SHARP CORNERS WITH 0.40 mm. 3. TOLERANCES WILL BE AS PER ANSI:H35.2-2009 UNLESS OTHERWISE SPECIFIED		SCALE 1:1		CHECKED B.NATARAJA 24-04-2020	APPROVED B.NATARAJA
PARTY'S NAME PERMACORP GROUP OF COMPANIES., CANADA		AREA mm ² 2545.477		PERIMETER mm. 613.052	
PARTY'S DRAWING No. H010773		WEIGHT kg/m 6.873		DRAWING No. P-20915	
ALLOY & TEMPER 6005 T5		SECTION No. -		DRAWING No. X2645	
DESCRIPTION MISC. SECTION					