

P-20937-1

X2650

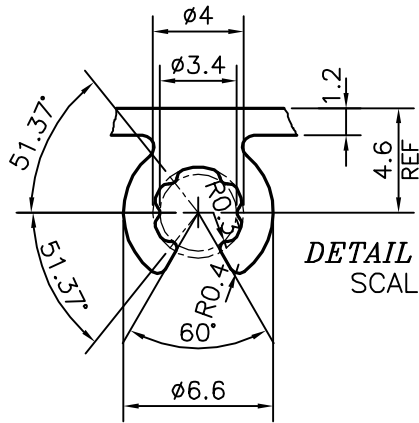

DETAIL OF "A"
SCALE 3:1

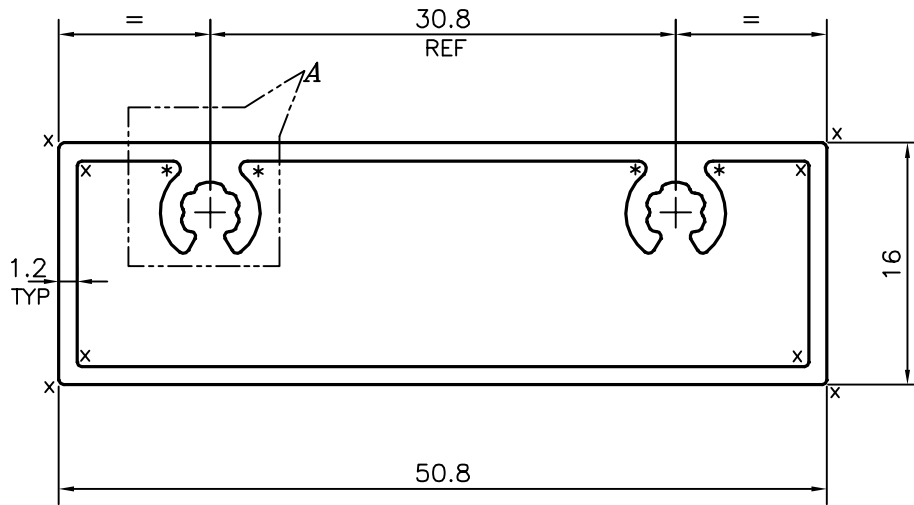
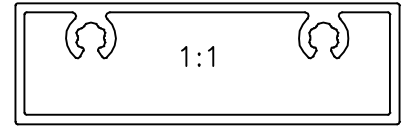

TOLERANCE CHART CD = CIRCUMSCRIBING CIRCLE

	CD ≤ 100	100 < CD ≤ 200	200 < CD ≤ 300	300 < CD ≤ 500
UPTO 10mm -	±0.25	±0.30	±0.35	±0.40
10.0 -25.0 -	±0.30	±0.40	±0.50	±0.60
25.0 -50.0 -	±0.50	±0.60	±0.80	±0.90
50.0 -100.0 -	±0.70	±0.90	±1.10	±1.30
100 - 150 -	-	±1.10	±1.30	±1.50
150 - 200 -	-	±1.3	±1.50	±1.80
200 - 300 -	-	-	±1.70	±2.10
300 - 450 -	-	-	-	±2.80

x = 0.30 RADIUS (8 PLACES)
* = 0.50 RADIUS (4 PLACES)



SYMBOL OF QUALITY
AN ISO 9001 COMPANY

JINDAL ALUMINIUM LTD.
BANGALORE-560073 (INDIA)

	NAME	DATE
DRAWN	J.P.KAUSHIK	09-05-2020
CHECKED		
APPROVED	B.NATARAJA	25-05-2020
SCALE		2:1
AREA mm ²		195.047
PERIMETER mm.		133.085
WEIGHT kg/m		0.527
DRAWING No.	SECTION No.	
P-20937-1	-	
X2650	X2650	

- ALL DIMENSIONS ARE IN mm.
- ROUND OFF ALL SHARP CORNERS WITH 0.40 mm.
- TOLERANCES WILL BE AS PER BS:EN-755-9, UNLESS OTHERWISE SPECIFIED

PARTY'S NAME	PERFECT GLAZE, UNITED KINGDOM
PARTY'S DRAWING No.	U108s
ALLOY & TEMPER	6063 T6
DESCRIPTION	MISC. TUBE