

P-21048

X2672

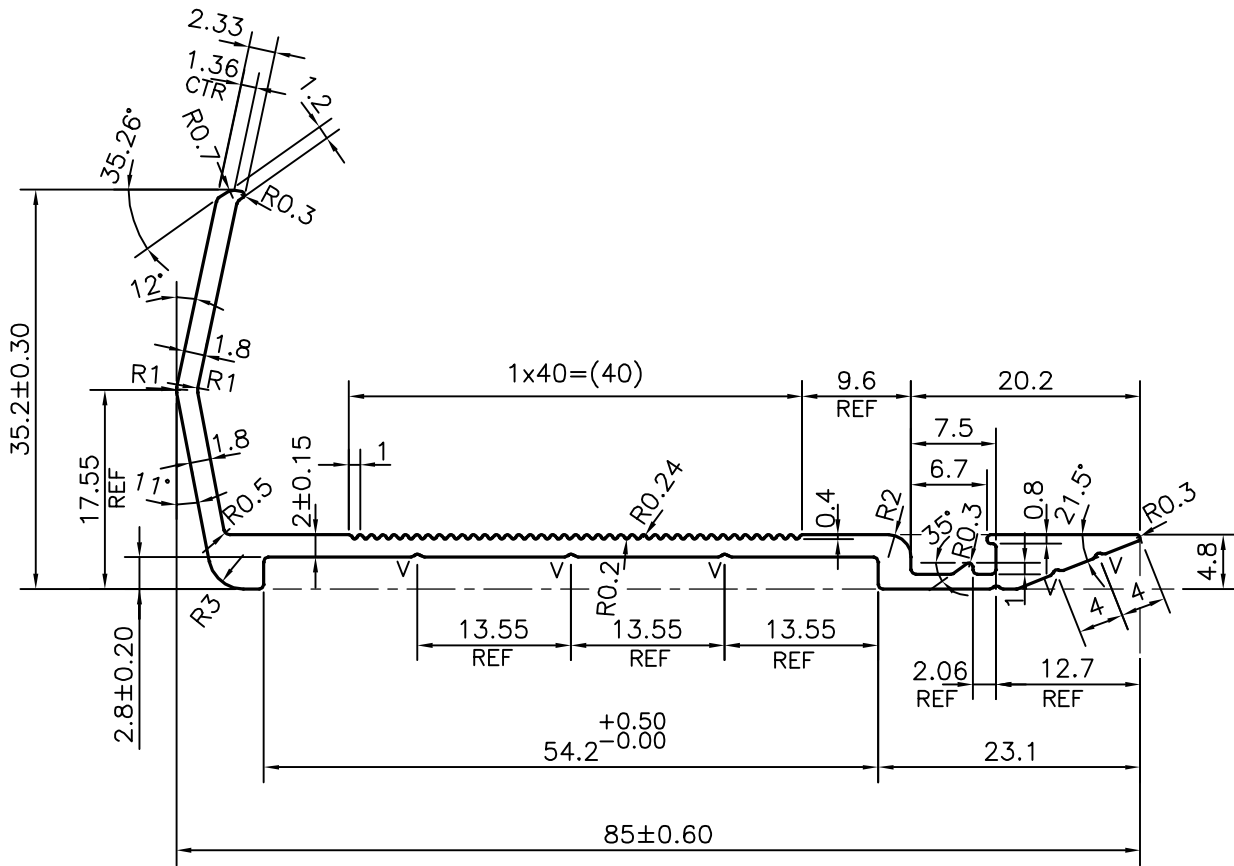

V = V GROOVE 0.3x90° (5 PAGES)

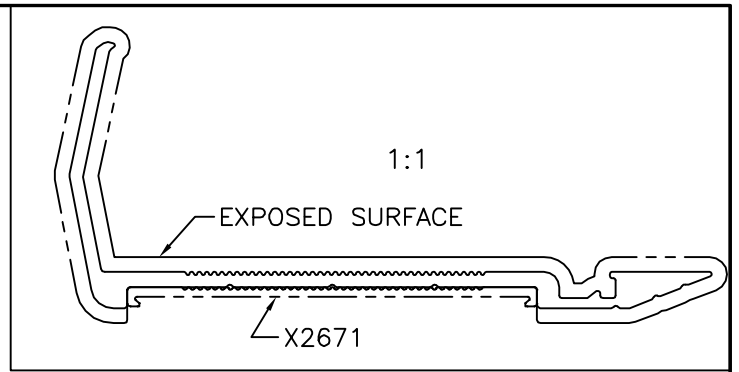

SYMBOL OF QUALITY
AN ISO 9001 COMPANY

JINDAL ALUMINIUM LTD.
BANGALORE-560073 (INDIA)

| | NAME | DATE |
|----------|-------------|------------|
| DRAWN | J.P.KAUSHIK | 06-06-2020 |
| CHECKED | | |
| APPROVED | B.NATARAJA | 15-06-2020 |

1. ALL DIMENSIONS ARE IN mm.
2. ROUND OFF ALL SHARP CORNERS WITH 0.40 mm.
3. TOLERANCES WILL BE AS PER AS/NZS:1866-1997, UNLESS OTHERWISE SPECIFIED

| | |
|----------------------|---------|
| SCALE | 1.5:1 |
| AREA mm ² | 239.297 |
| PERIMETER mm. | 259.511 |
| WEIGHT kg/m | 0.646 |

| | |
|---------------------|--|
| PARTY'S NAME | WALMAY ARCHITECTURAL PRODUCTS, AUSTRALIA |
| PARTY'S DRAWING No. | CA0002003 |
| ALLOY & TEMPER | 6060 T5 |
| DESCRIPTION | 10 BASE PROFILE |

| DRAWING No. | SECTION No. |
|-------------|-------------|
| P-21048 | - |
| X2672 | X2672 |
| | |
| | |