

P-21049

X2673

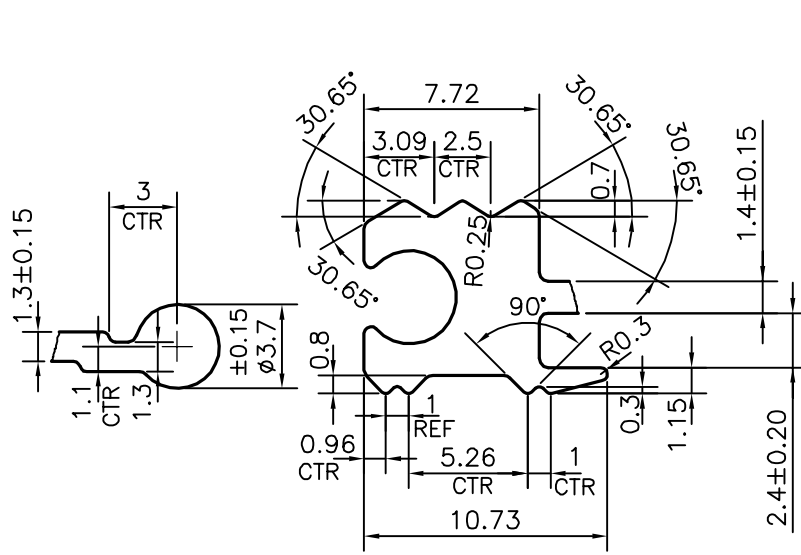

SCALE: - 1:2

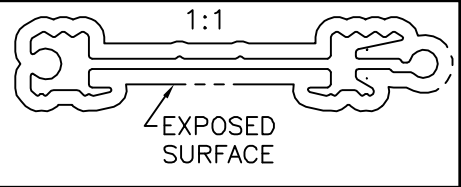

DETAIL OF "A"  
SCALE 3:1

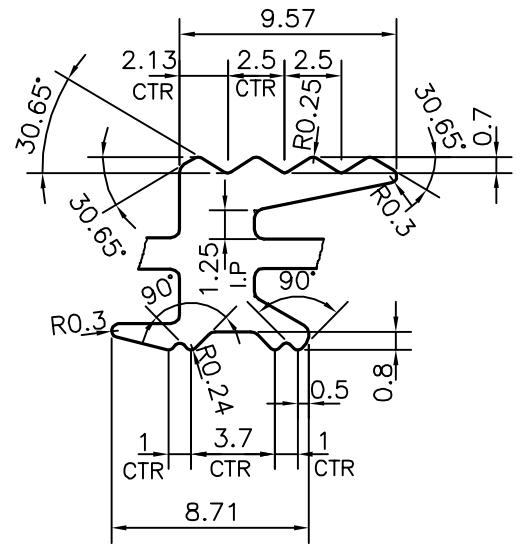

DETAIL OF "B"  
SCALE 3:1

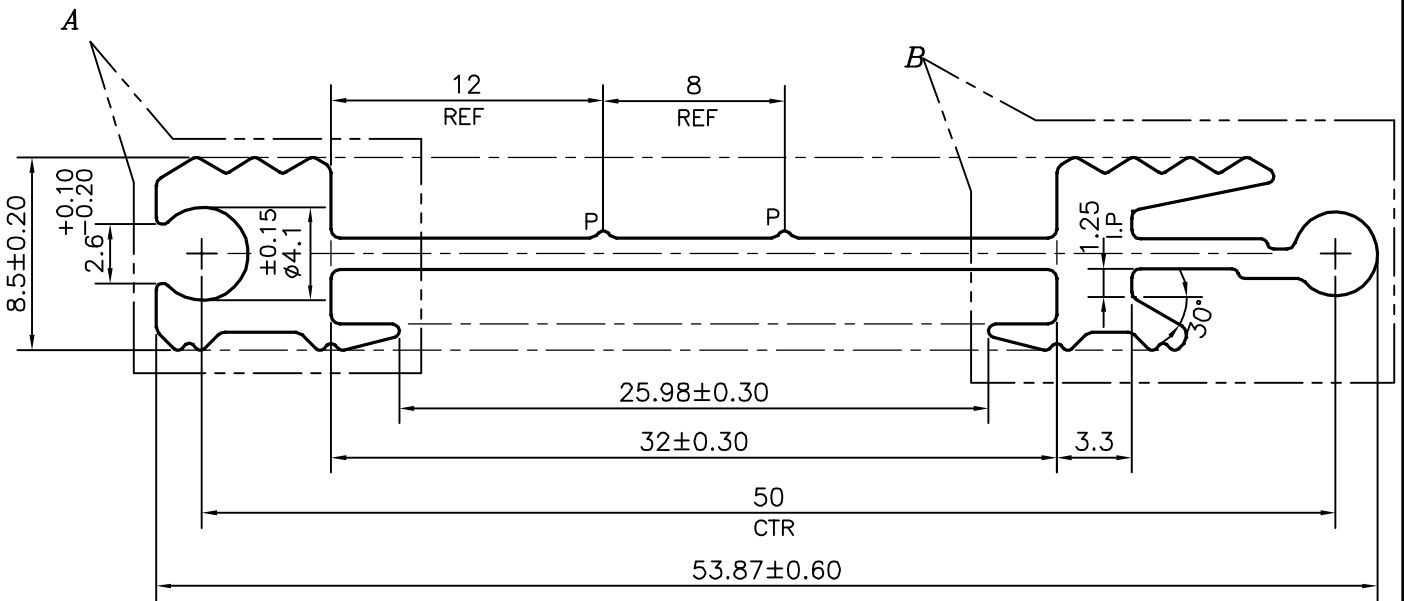

P = PIP 0.3x90° (2 PACES)



SYMBOL OF QUALITY  
AN ISO 9001 COMPANY

**JINDAL ALUMINIUM LTD.**  
BANGALORE-560073 (INDIA)

	NAME	DATE
DRAWN	J.P.KAUSHIK	06-06-2020
CHECKED		
APPROVED	B.NATARAJA	15-06-2020

1. ALL DIMENSIONS ARE IN mm.
2. ROUND OFF ALL SHARP CORNERS WITH 0.40 mm.
3. TOLERANCES WILL BE AS PER AS/NZS:1866-1997, UNLESS OTHERWISE SPECIFIED

SCALE	3:1
AREA mm <sup>2</sup>	153.717
PERIMETER mm.	174.85
WEIGHT kg/m	0.415

PARTY'S NAME	WALMAY ARCHITECTURAL PRODUCTS, AUSTRALIA
PARTY'S DRAWING No.	CA0001689
ALLOY & TEMPER	6063 T5
DESCRIPTION	ENTRYMAT ALPHA 1

DRAWING No.	SECTION No.
P-21049	-
X2673	X2673