

P-21330

X2701

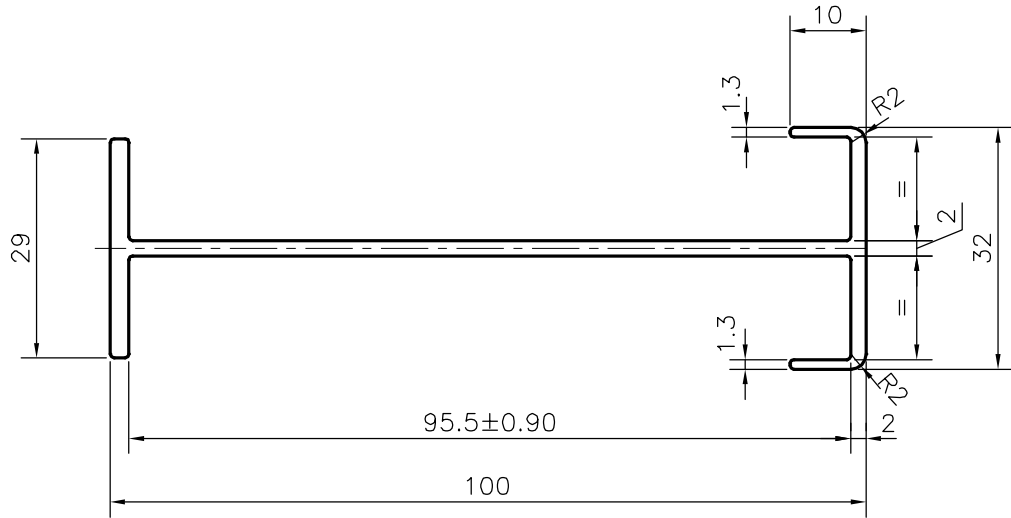

UNSPECIFIED RADIUS 0.50 mm



SYMBOL OF QUALITY
AN ISO 9001 COMPANY

JINDAL ALUMINIUM LTD.
BANGALORE-560073 (INDIA)

	NAME	DATE
DRAWN	J.P.KAUSHIK	18-08-2020
CHECKED		
APPROVED	J.N.RAI	29-08-2020

1. ALL DIMENSIONS ARE IN mm.
2. ROUND OFF ALL SHARP CORNERS WITH 0.40 mm.
3. TOLERANCES WILL BE AS PER **AS/NZS:1866-1997** UNLESS OTHERWISE SPECIFIED

SCALE	1:1
AREA mm ²	346.476
PERIMETER mm.	345.279
WEIGHT kg/m	0.935

PARTY'S NAME	WAKEFIELD METALS, NEW ZEALAND	DRAWING No.	P-21330	SECTION No.	-
PARTY'S DRAWING No.	EM_N16A_EX		X2701		X2701
ALLOY & TEMPER	6060 T5				
DESCRIPTION	SIDE RAIL-N16A				