

P-21639-1

X2714

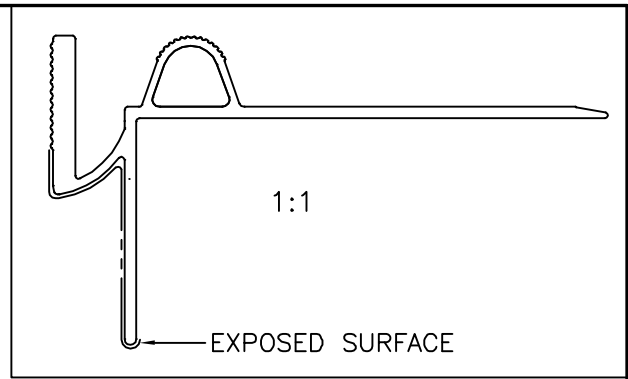

DETAIL OF "A"
SCALE 3:1

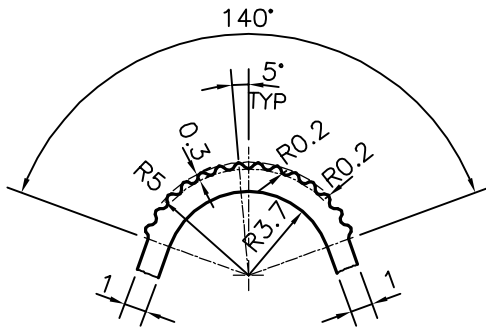
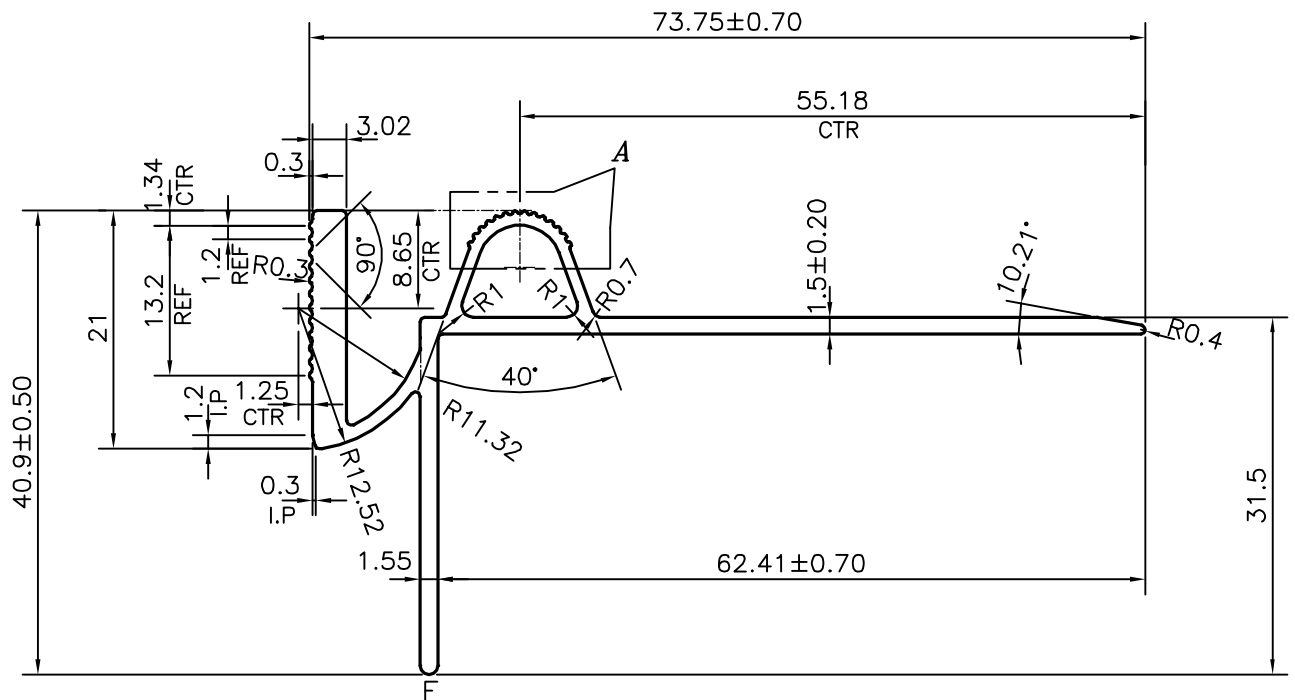

AVERAGE WEIGHT:-0.562 kg/m TO 0.735 kg/m

F = FULL RADIUS (1 PLACE)



SYMBOL OF QUALITY
AN ISO 9001 COMPANY

JINDAL ALUMINIUM LTD.
BANGALORE-560073 (INDIA)

	NAME	DATE
DRAWN	J.P.KAUSHIK	20-10-2020
CHECKED		
APPROVED	B.NATARAJA	23-10-2020
SCALE		1.5:1
AREA mm ²		241.81
PERIMETER mm.		264.777
WEIGHT kg/m		0.653
DRAWING No.	SECTION No.	
P-21639-1	-	
X2714	X2714	

1. ALL DIMENSIONS ARE IN mm.
2. ROUND OFF ALL SHARP CORNERS WITH 0.40 mm.
3. TOLERANCES WILL BE AS PER,BS:EN-12020-2 UNLESS OTHERWISE SPECIFIED

PARTY'S NAME	THYSSENKRUPP MATERIALS, BELGIUM SA
PARTY'S DRAWING No.	EL7342
ALLOY & TEMPER	6060 T66
DESCRIPTION	MISC. SECTION