

P-21730

X2715

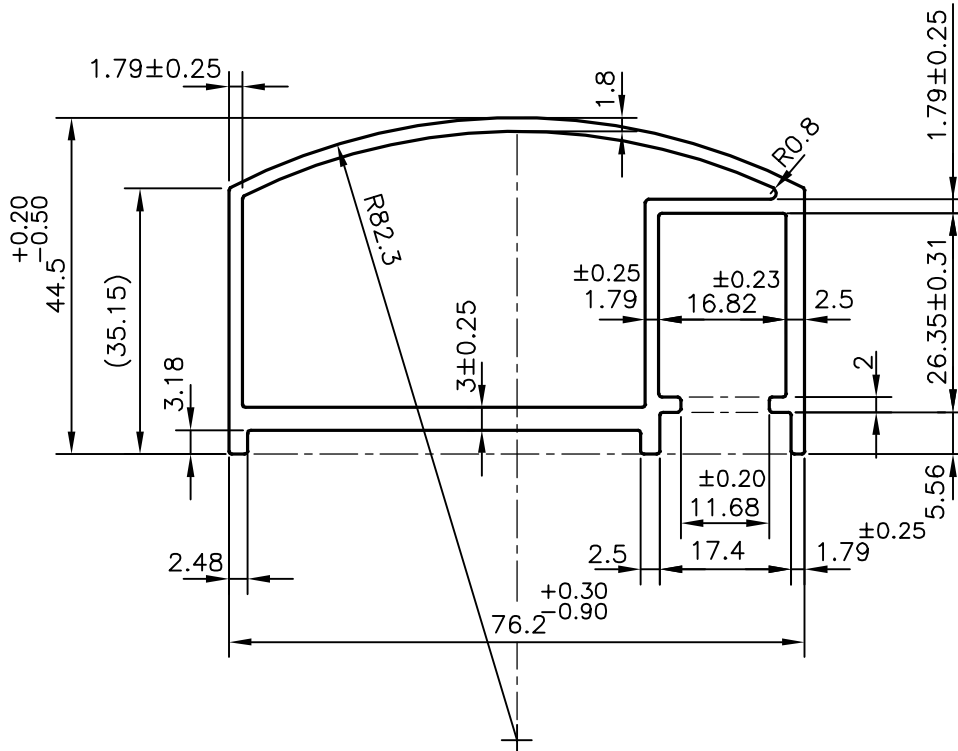

AVERAGE WEIGHT:-1.277 kg/m TO 1.692 kg/m

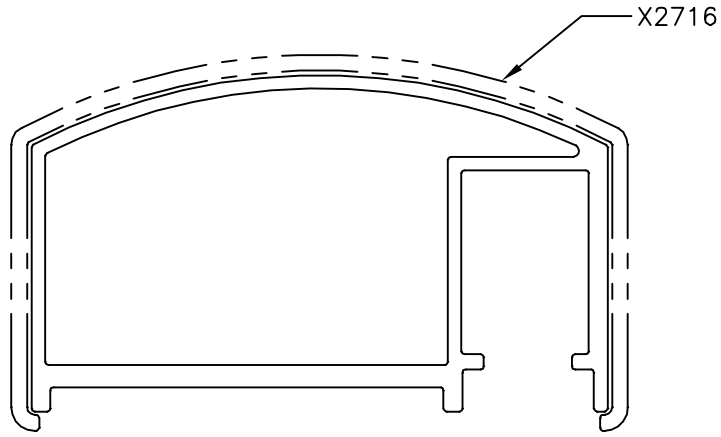

SYMBOL OF QUALITY
AN ISO 9001 COMPANY

JINDAL ALUMINIUM LTD.
BANGALORE-560073 (INDIA)

	NAME	DATE
DRAWN	J.P.KAUSHIK	30-10-2020
CHECKED		
APPROVED	B.NATARAJA	04-11-2020

1. ALL DIMENSIONS ARE IN mm.
2. ROUND OFF ALL SHARP CORNERS WITH 0.40 mm.
3. TOLERANCES WILL BE AS PER BS:EN-755-9 ,UNLESS OTHERWISE SPECIFIED

SCALE	1:1
AREA mm ²	550.102
PERIMETER mm.	302.995
WEIGHT kg/m	1.485

PARTY'S NAME	PERMACORP GROUP OF COMPANIES, ALBERTA
PARTY'S DRAWING No.	AS PER DRAWING
ALLOY & TEMPER	6063 T5
DESCRIPTION	HAND RAIL SECTION

DRAWING No.	SECTION No.
P-21730	-
X2715	X2715