

P-21731

X2716

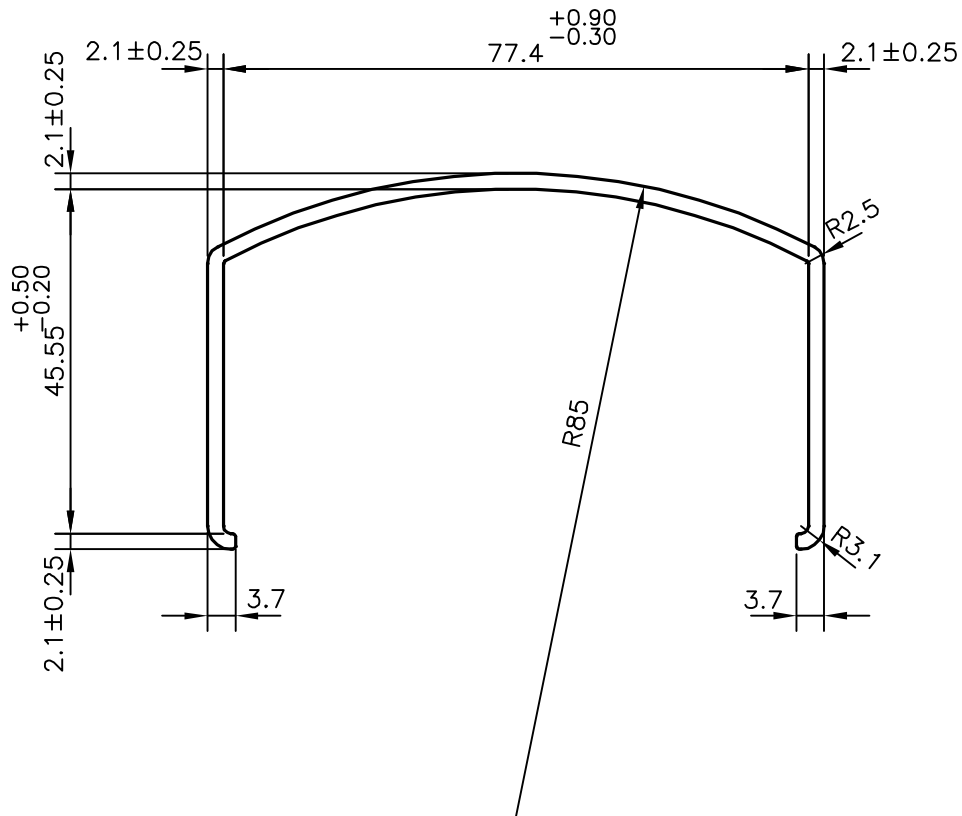

AVERAGE WEIGHT:-0.805 kg/m TO 1.022 kg/m

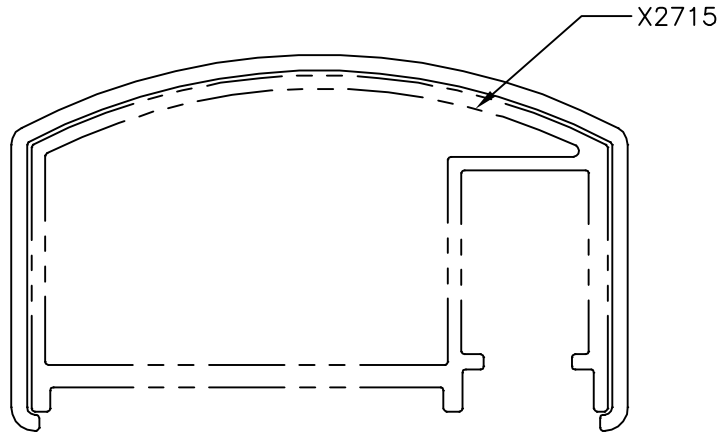

SYMBOL OF QUALITY  
AN ISO 9001 COMPANY

**JINDAL ALUMINIUM LTD.**  
BANGALORE-560073 (INDIA)

	NAME	DATE
DRAWN	J.P.KAUSHIK	30-10-2020
CHECKED		
APPROVED	B.NATARAJA	04-11-2020
SCALE		1:1
AREA mm <sup>2</sup>		338.584
PERIMETER mm.		326.105
WEIGHT kg/m		0.914
DRAWING No.	SECTION No.	
P-21731	-	
X2716	X2716	

1. ALL DIMENSIONS ARE IN mm.
2. ROUND OFF ALL SHARP CORNERS WITH 0.40 mm.
3. TOLERANCES WILL BE AS PER BS:EN-755-9 ,UNLESS OTHERWISE SPECIFIED

PARTY'S NAME	PERMACORP GROUP OF COMPANIES, ALBERTA
PARTY'S DRAWING No.	AS PER DRAWING
ALLOY & TEMPER	6063 T5
DESCRIPTION	MISC. CHANNEL