

P-21637-1

X2718

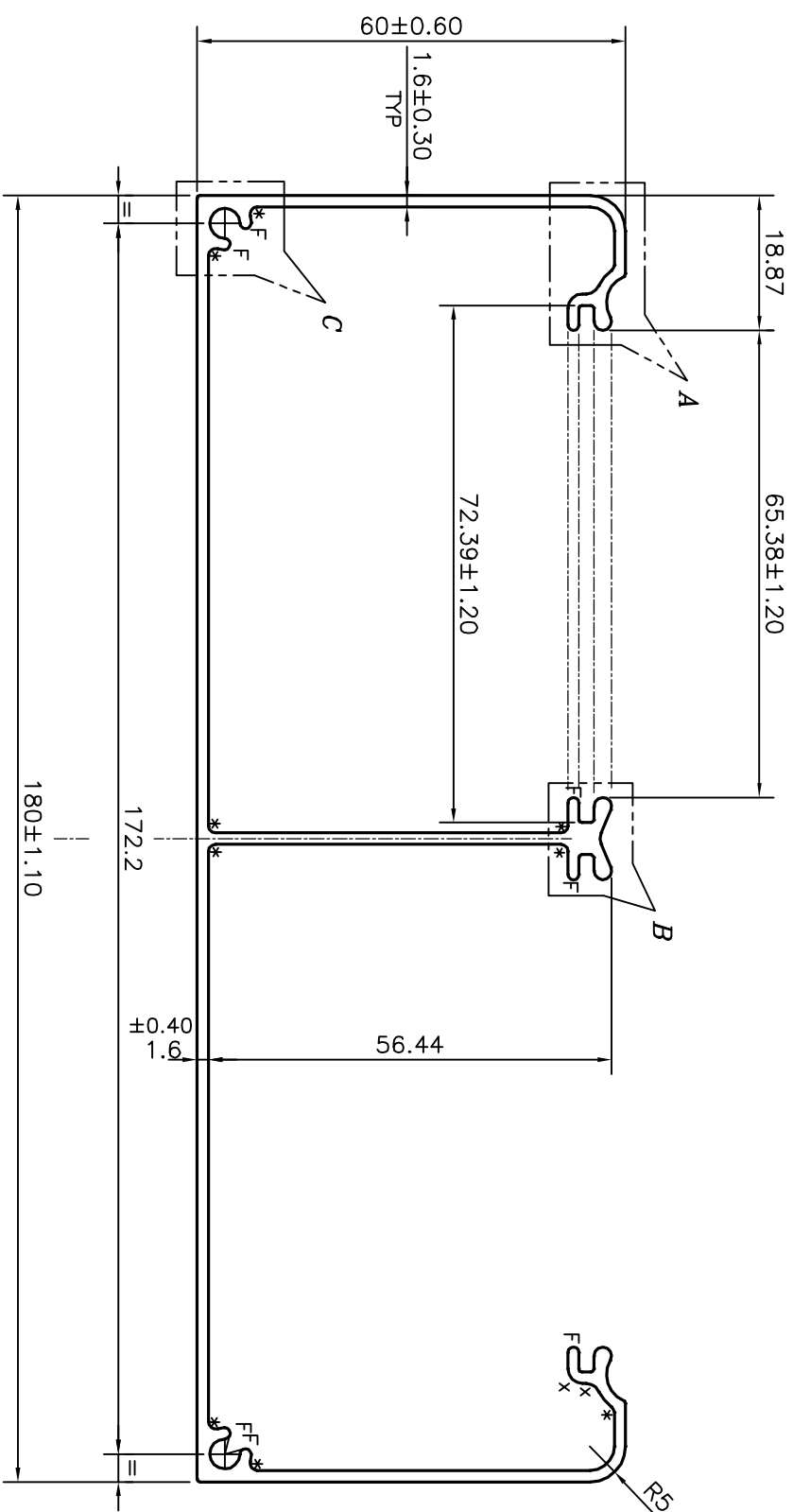

DETAIL OF "A"
SCALE:- 3:1

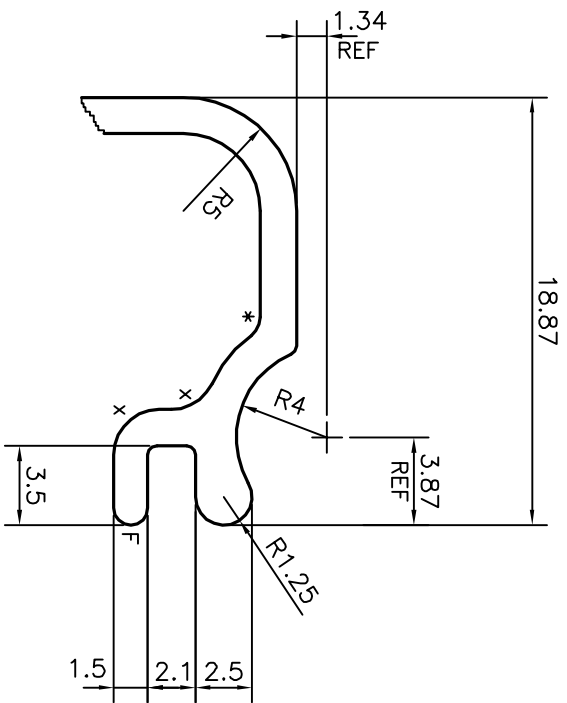
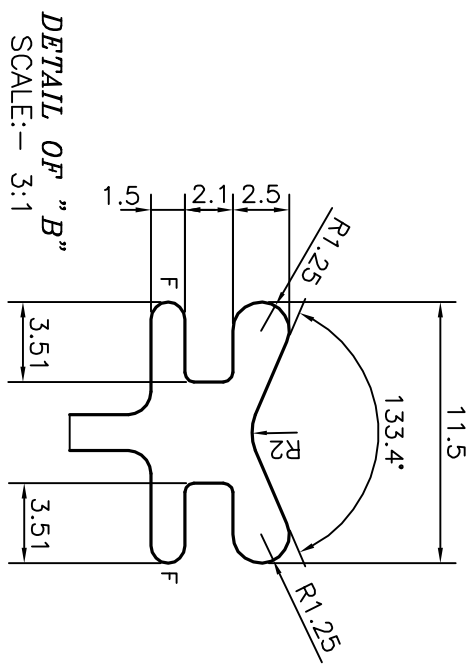
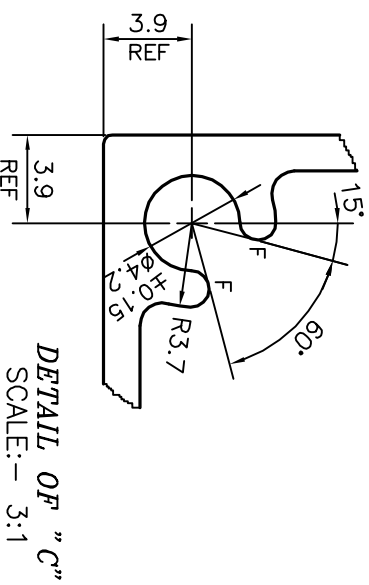

AVERAGE WEIGHT:-1.719 kg/m TO 2.099 kg/m

x = 2.0 RADIUS (4 PLACES)
* = 1.0 RADIUS (10 PLACES)
F = FULL RADIUS (8 PLACES)

 JINDAL ALUMINIUM LTD. BANGALORE-560073 (INDIA)		SYMBOL OF QUALITY AN ISO 9001 COMPANY
1. ALL DIMENSIONS ARE IN mm. 2. ROUND OFF ALL SHARP CORNERS WITH 0.40 mm. 3. TOLERANCES WILL BE AS PER AS/NZS:1866-1997 UNLESS OTHERWISE SPECIFIED		
PARTY'S NAME	WAKEFIELD METALS, NEW ZEALAND	
PARTY'S DRAWING No.	EM-TCDD 180X60 AL/1	
ALLOY & TEMPER	6063 T6	
DESCRIPTION	SKIRTING DUCT SECTION	
DRAWN	NAME	DATE
CHECKED	J.P.KAUSHIK	09-10-2020
APPROVED	B.NATARAJA	06-11-2020
SCALE	1:1	
AREA	mm ²	707.075
PERIMETER	mm.	841.956
WEIGHT	kg/m	1.909
DRAWING No.	SECTION No.	
P-21637-1	-	
X2718	X2718	