

P-21662

X2719

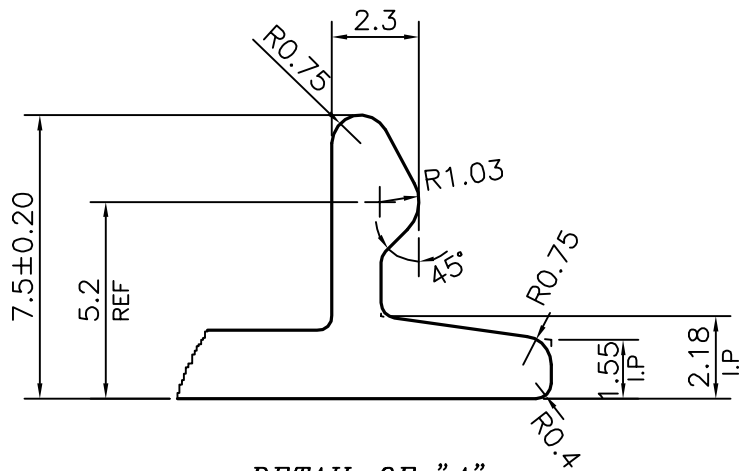

DETAIL OF "A"
SCALE:- 5:1

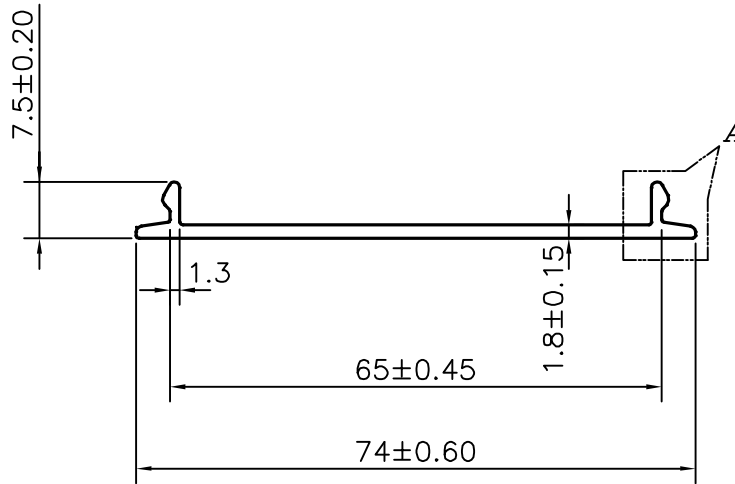

AVERAGE WEIGHT:-0.370 kg/m TO 0.452 kg/m



SYMBOL OF QUALITY
AN ISO 9001 COMPANY

JINDAL ALUMINIUM LTD.
BANGALORE-560073 (INDIA)

	NAME	DATE
DRAWN	J.P.KAUSHIK	09-10-2020
CHECKED		
APPROVED	B.NATARAJA	06-11-2020
SCALE		1:1
AREA	mm ²	152.328
PERIMETER	mm.	172.05
WEIGHT	kg/m	0.411
DRAWING No.	SECTION No.	
P-21662	-	
X2719	X2719	

1. ALL DIMENSIONS ARE IN mm.
2. ROUND OFF ALL SHARP CORNERS WITH 0.40 mm.
3. TOLERANCES WILL BE AS PER AS/NZS:1866-1997 UNLESS OTHERWISE SPECIFIED

PARTY'S NAME	WAKEFIELD METALS, NEW ZEALAND
PARTY'S DRAWING No.	V-20-30175
ALLOY & TEMPER	6063 T5
DESCRIPTION	CLIP SECTION