

P-21496-1

X2723

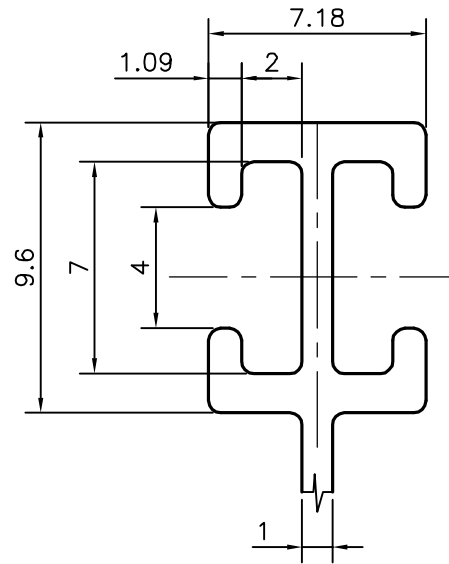

DETAILS OF "A"
SCALE 4:1

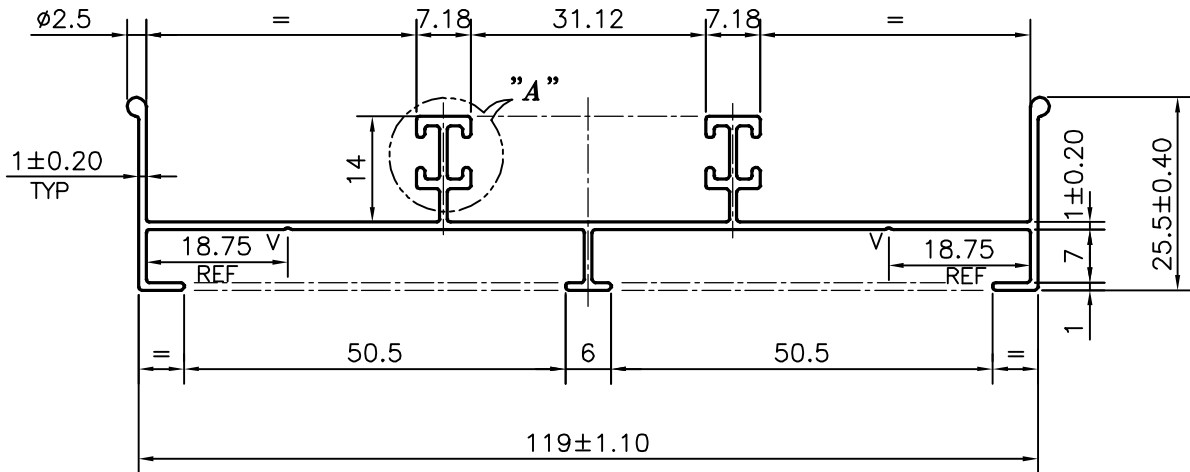

AVERAGE WEIGHT: -0.654 kg/m TO 0.800 kg/m

V = V GROOVE 0.3x90° (2 PLACES)



SYMBOL OF QUALITY
AN ISO 9001 COMPANY

JINDAL ALUMINIUM LTD.
BANGALORE-560073 (INDIA)

	NAME	DATE
DRAWN	J.P.KAUSHIK	08-10-2020
CHECKED		
APPROVED	B.NATARAJA	09-11-2020

1. ALL DIMENSIONS ARE IN mm.
2. ROUND OFF ALL SHARP CORNERS WITH 0.40 mm.
3. TOLERANCES WILL BE AS PER BS:EN-755-9, UNLESS OTHERWISE SPECIFIED

SCALE	1:1
AREA mm ²	269.433
PERIMETER mm.	504.593
WEIGHT kg/m	0.727

PARTY'S NAME	PRAYOSHA ENTERPRISES LTD., UGANDA
PARTY'S DRAWING No.	MODIFIED OF 21440
ALLOY & TEMPER	6063 T6
DESCRIPTION	WINDOW SECTION (3 TRACK VERTICAL)

DRAWING No.	SECTION No.
P-21496-1	-
X2723	X2723