

P-21497-1

X2724

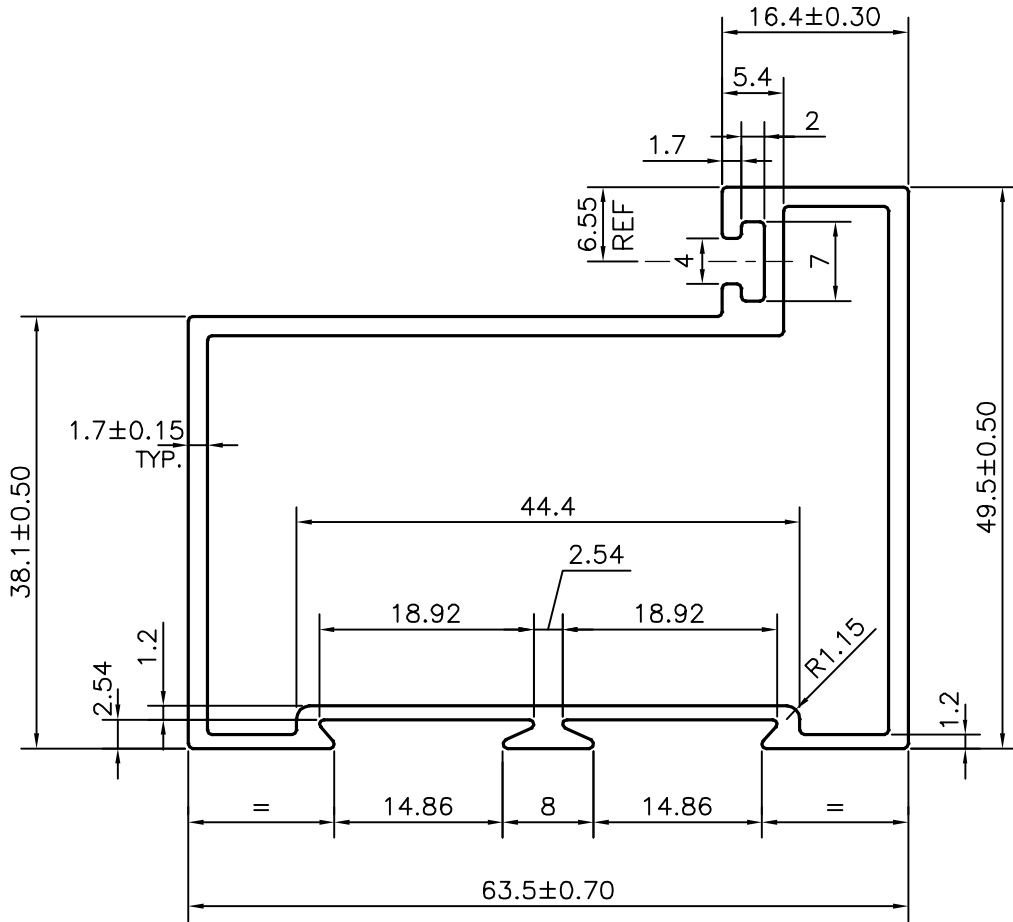

AVERAGE WEIGHT:-0.949 kg/m TO 1.159 kg/m

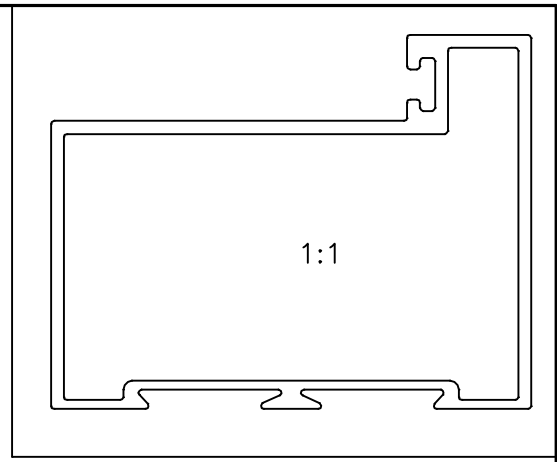

SYMBOL OF QUALITY
AN ISO 9001 COMPANY

JINDAL ALUMINIUM LTD.
BANGALORE-560073 (INDIA)

	NAME	DATE
DRAWN	J.P.KAUSHIK	24-09-2020
CHECKED		
APPROVED	B.NATARAJA	09-11-2020
SCALE		1.5:1
AREA mm ²		390.446
PERIMETER mm.		258.197
WEIGHT kg/m		1.054
DRAWING No.		SECTION No.
P-21497-1		-
X2724		X2724

1. ALL DIMENSIONS ARE IN mm.
2. ROUND OFF ALL SHARP CORNERS WITH 0.40 mm.
3. TOLERANCES WILL BE AS PER BS:EN-755-9, UNLESS OTHERWISE SPECIFIED

PARTY'S NAME	PRAYOSHA ENTERPRISES LTD., UGANDA
PARTY'S DRAWING No.	MODIFIED OF 20024
ALLOY & TEMPER	6063 T6
DESCRIPTION	WINDOW SECTION