

P-21503-2

X2730

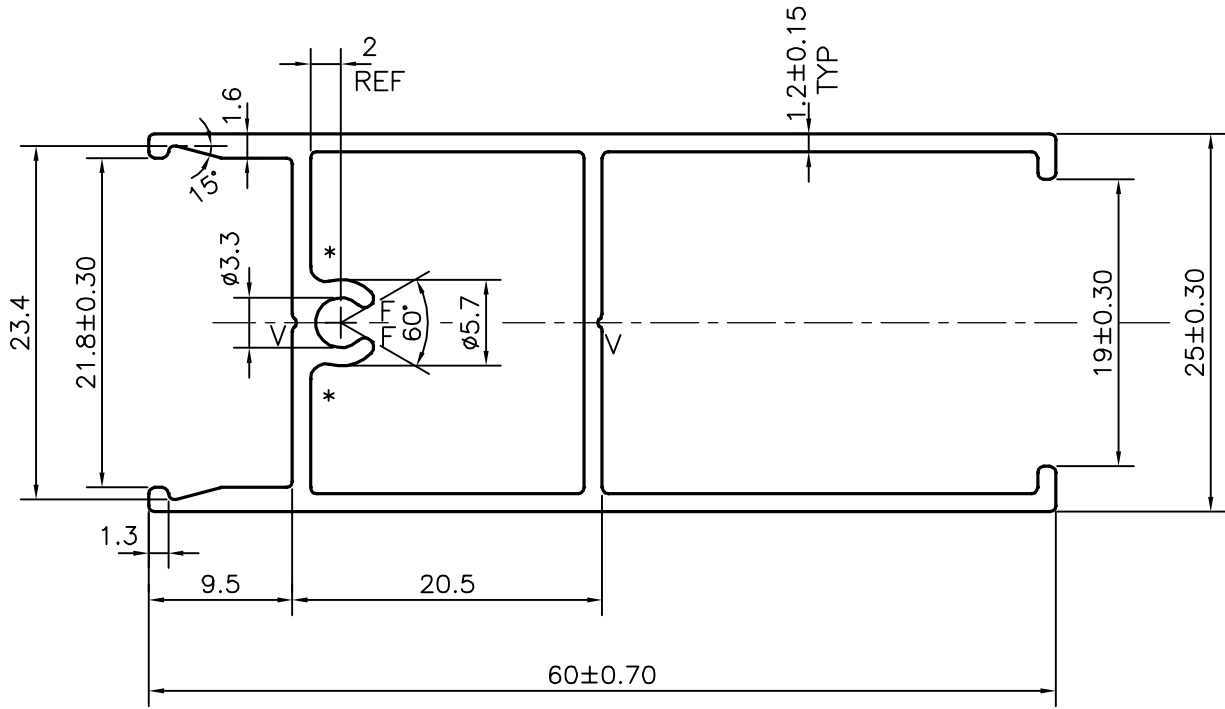
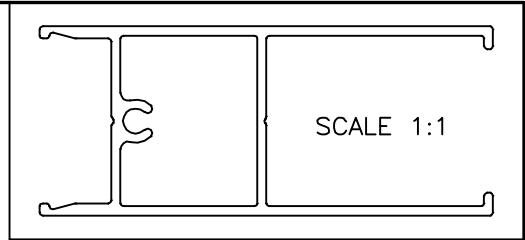

* = 1.0 RADIUS (2 PLACES)

F = FULL RADIUS (2 PLACES)

V = V GROOVE $0.3 \times 90^\circ$ (2 PLACES)

AVERAGE WEIGHT: -0.518 kg/m TO 0.666 kg/m



SYMBOL OF QUALITY
AN ISO 9001 COMPANY

JINDAL ALUMINIUM LTD.
BANGALORE-560073 (INDIA)

	NAME	DATE
DRAWN	J.P.KAUSHIK	16-10-2020
CHECKED		
APPROVED	B.NATARAJA	09-11-2020
SCALE		2:1
AREA mm ²		219.218
PERIMETER mm.		254.951
WEIGHT kg/m		0.592
DRAWING No.		SECTION No.
P-21503-2		-
X2730		X2730

1. ALL DIMENSIONS ARE IN mm.
2. ROUND OFF ALL SHARP CORNERS WITH 0.40 mm.
3. TOLERANCES WILL BE AS PER BS:EN-755-9, UNLESS OTHERWISE SPECIFIED

PARTY'S NAME	PRAYOSHA ENTERPRISES LTD., UGANDA
PARTY'S DRAWING No.	MODIFIED OF 20639
ALLOY & TEMPER	6063 T6
DESCRIPTION	WINDOW SECTION