

P-21506-1

X2733

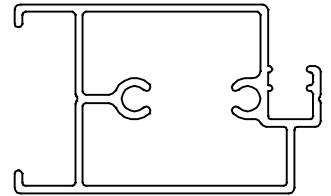

SCALE 1:1

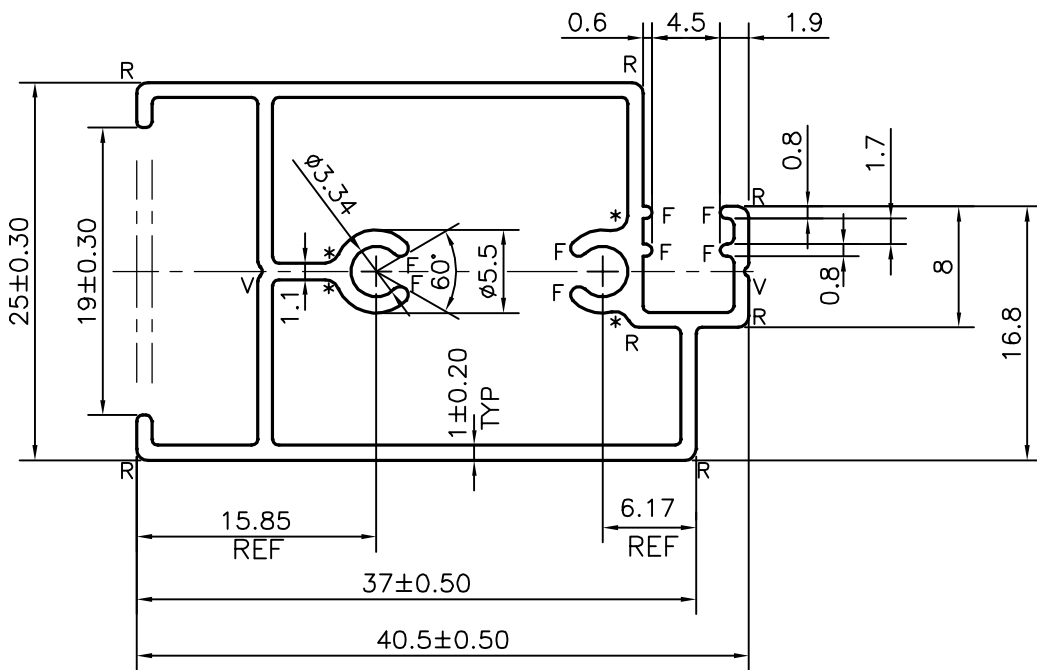

- * = RADIUS 1.0mm (4 PLACES)
- R = RADIUS 0.75mm (7 PLACES)
- F = FULL RADIUS (8 PLACES)
- V = V-GROOVE 0.3x90°(2 PLACES)

AVERAGE WEIGHT:-0.395 kg/m TO 0.483 kg/m



SYMBOL OF QUALITY
AN ISO 9001 COMPANY

JINDAL ALUMINIUM LTD.
BANGALORE-560073 (INDIA)

	NAME	DATE
DRAWN	J.P.KAUSHIK	08-10-2020
CHECKED		
APPROVED	B.NATARAJA	09-11-2020

1. ALL DIMENSIONS ARE IN mm.
2. ROUND OFF ALL SHARP CORNERS WITH 0.40 mm.
3. TOLERANCES WILL BE AS PER BS:EN-755-9, UNLESS OTHERWISE SPECIFIED

SCALE	2:1
AREA mm ²	162.499
PERIMETER mm.	169.66
WEIGHT kg/m	0.439

PARTY'S NAME	PRAYOSHA ENTERPRISES LTD., UGANDA
PARTY'S DRAWING No.	MODIFIED OF 21443
ALLOY & TEMPER	6063 T6
DESCRIPTION	WINDOW SECTION (MOSQUITO PLAIN)

DRAWING No.	SECTION No.
P-21506-1	-
X2733	X2733