

P-21574-2

X2735

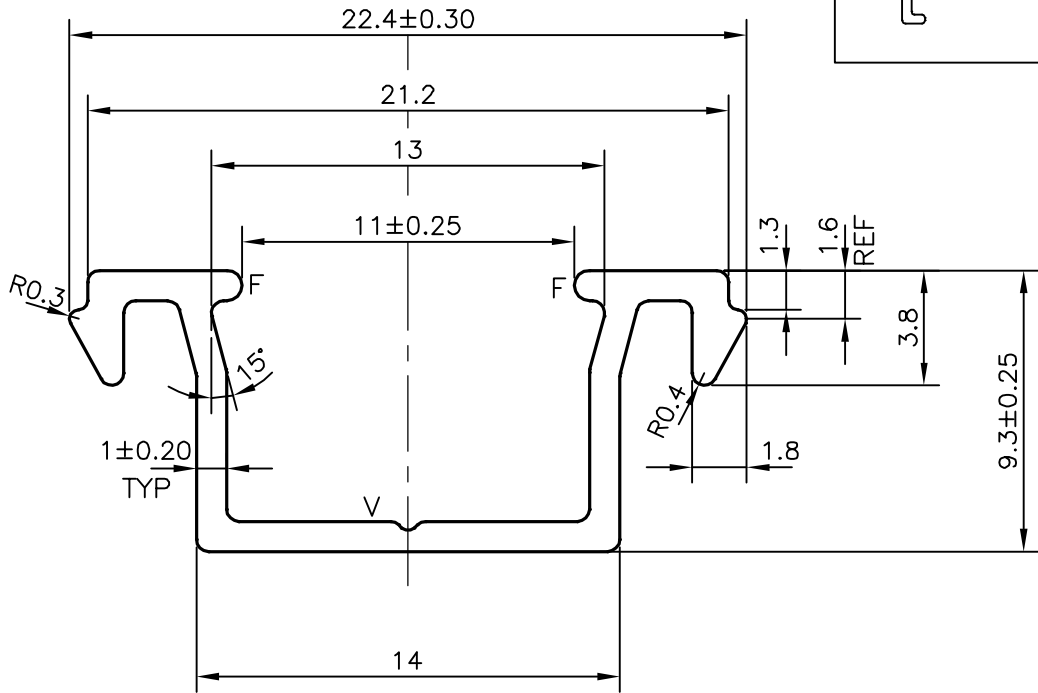
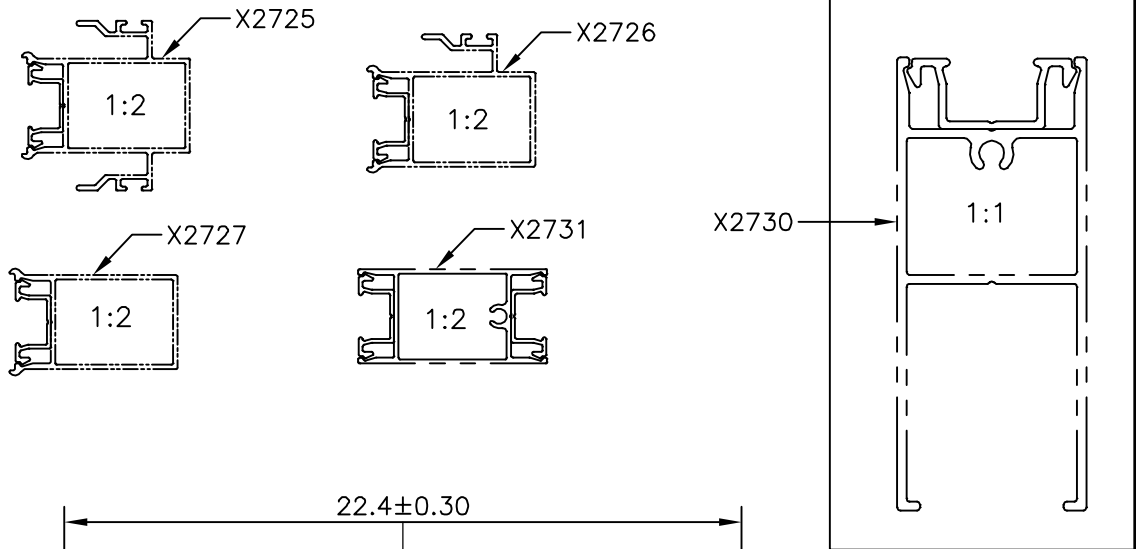

AVERAGE WEIGHT:-0.099 kg/m TO 0.149 kg/m

V = V GROOVE 0.3x90° (1 PLACE)

F = FULL RADIUS (2 PLACES)



SYMBOL OF QUALITY
AN ISO 9001 COMPANY

JINDAL ALUMINIUM LTD.
BANGALORE-560073 (INDIA)

	NAME	DATE
DRAWN	J.P.KAUSHIK	22-10-2020
CHECKED		
APPROVED	B.NATARAJA	09-11-2020

1. ALL DIMENSIONS ARE IN mm.
2. ROUND OFF ALL SHARP CORNERS WITH 0.40 mm.
3. TOLERANCES WILL BE AS PER BS:EN-755-9 UNLESS OTHERWISE SPECIFIED

SCALE	4:1
AREA mm ²	45.909
PERIMETER mm.	87.933
WEIGHT kg/m	0.124

PARTY'S NAME	PRAYOSHA ENTERPRISES LTD.,UGANDA	DRAWING No.	P-21574-2	SECTION No.	-
PARTY'S DRAWING No.	AS PER DRAWING		X2735		X2735
ALLOY & TEMPER	6063 T6				
DESCRIPTION	WINDOW SECTION				