

P-21577-1

X2738

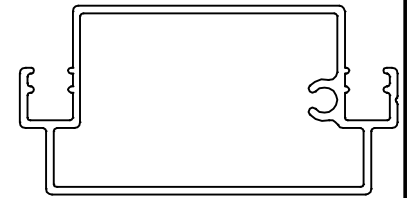

SCALE 1:1

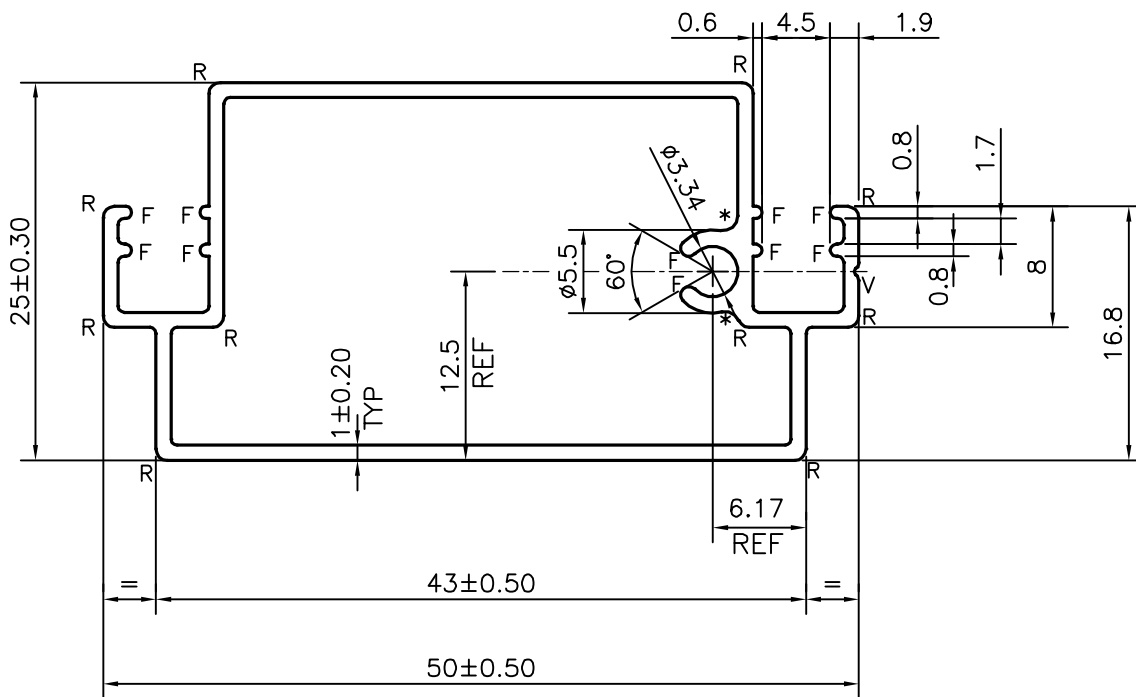

V = V GROOVE 0.3x90° (1 PLACE)

* = RADIUS 1.0mm (2 PLACES)

R = RADIUS 0.75mm (10 PLACES)

F = FULL RADIUS (10 PLACES)

AVERAGE WEIGHT:-0.404 kg/m TO 0.494 kg/m



SYMBOL OF QUALITY
AN ISO 9001 COMPANY

JINDAL ALUMINIUM LTD.
BANGALORE-560073 (INDIA)

	NAME	DATE
DRAWN	J.P.KAUSHIK	08-10-2020
CHECKED		
APPROVED	B.NATARAJA	09-11-2020

1. ALL DIMENSIONS ARE IN mm.
2. ROUND OFF ALL SHARP CORNERS WITH 0.40 mm.
3. TOLERANCES WILL BE AS PER BS:EN-755-9, UNLESS OTHERWISE SPECIFIED

SCALE	2:1
AREA mm ²	166.184
PERIMETER mm.	182.806
WEIGHT kg/m	0.449

PARTY'S NAME PRAYOSHA ENTERPRISES LTD., UGANDA

DRAWING No. SECTION No.

PARTY'S DRAWING No. AS PER DRAWING

P-21577-1 -
X2738 X2738

ALLOY & TEMPER 6063 T6

DESCRIPTION WINDOW SECTION (MOSQUITO LOCKRAIL)