

P-21534-1

X2739

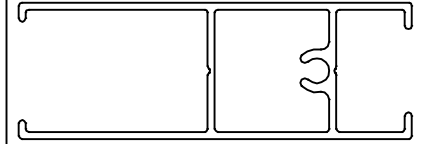

SCALE 1:1

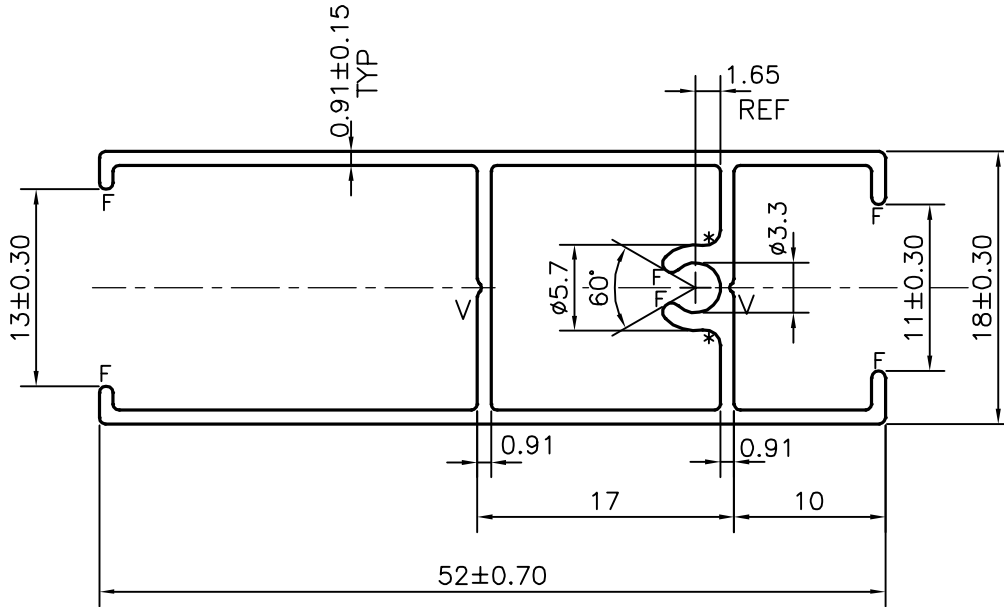

\* = 1.0 RADIUS (2 PLACES)

F = FULL RADIUS (6 PLACES)

V = V GROOVE 0.3x90° (2 PLACES)

AVERAGE WEIGHT:-0.345 kg/m TO 0.421 kg/m



SYMBOL OF QUALITY  
AN ISO 9001 COMPANY

**JINDAL ALUMINIUM LTD.**  
BANGALORE-560073 (INDIA)

	NAME	DATE
DRAWN	J.P.KAUSHIK	06-10-2020
CHECKED		
APPROVED	B.NATARAJA	10-11-2020

1. ALL DIMENSIONS ARE IN mm.
2. ROUND OFF ALL SHARP CORNERS WITH 0.40 mm.
3. TOLERANCES WILL BE AS PER BS:EN-755-9, UNLESS OTHERWISE SPECIFIED

SCALE	2:1
AREA mm <sup>2</sup>	142.025
PERIMETER mm.	223.474
WEIGHT kg/m	0.383

PARTY'S NAME	PRAYOSHA ENTERPRISES LTD., UGANDA
PARTY'S DRAWING No.	MODIFIED OF 20811
ALLOY & TEMPER	6063 T6
DESCRIPTION	WINDOW SECTION

DRAWING No.	SECTION No.
P-21534-1	-
X2739	X2739