

P-21590

X2749

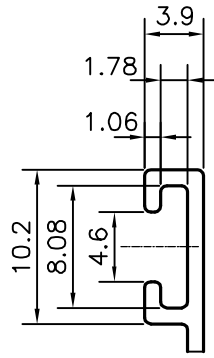

DETAIL OF "A"
SCALE:- 2:1

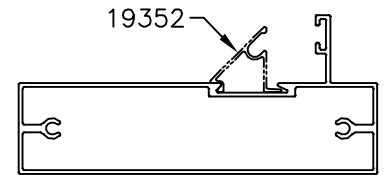

SCALE:- 1:2

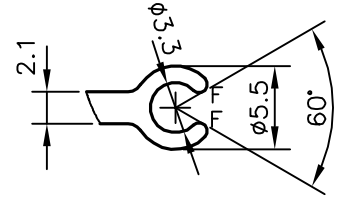

DETAIL OF "B"
SCALE:- 2:1

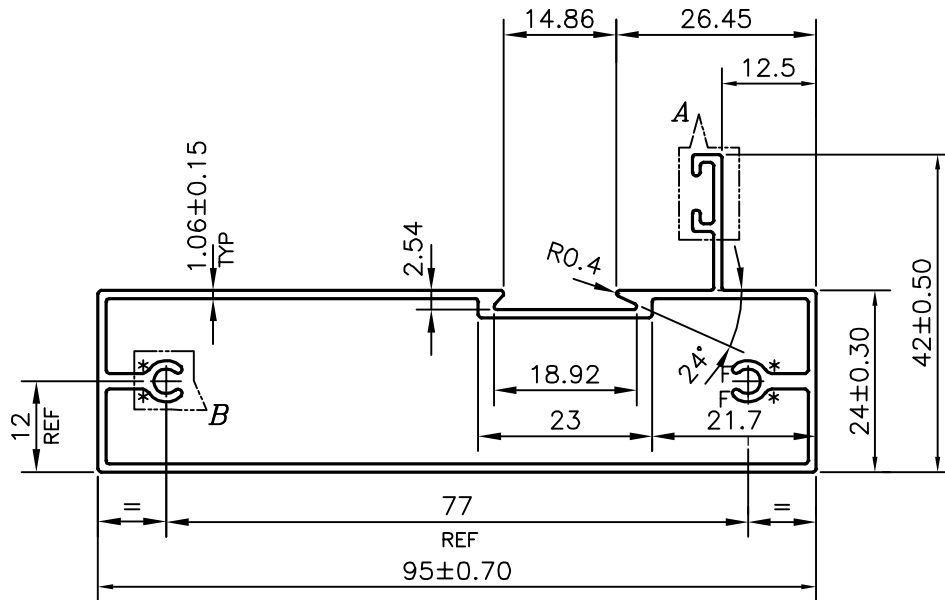

AVERAGE WEIGHT:-0.824 kg/m TO 1.008 kg/m

* = 1.0 RADIUS (4 PLACES)
F = FULL RADIUS (4 PLACES)

 SYMBOL OF QUALITY AN ISO 9001 COMPANY	JINDAL ALUMINIUM LTD. BANGALORE-560073 (INDIA)	NAME	DATE
		DRAWN	J.P.KAUSHIK 03-10-2020
		CHECKED	
		APPROVED	B.NATARAJA 10-11-2020
		SCALE	1:1
		AREA mm ²	339.33
		PERIMETER mm.	299.832
		WEIGHT kg/m	0.916
PARTY'S NAME	PRAYOSHA ENTERPRISES LTD., UGANDA	DRAWING No.	SECTION No.
PARTY'S DRAWING No.	MODIFIED OF 21463	P-21590	-
ALLOY & TEMPER	6063 T6	X2749	X2749
DESCRIPTION	WINDOW SECTION		