

P-21591-1

X2750

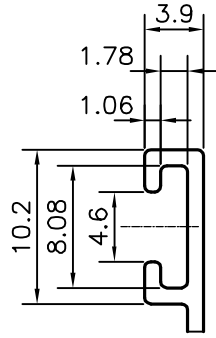

DETAIL OF "A"
SCALE:- 2:1

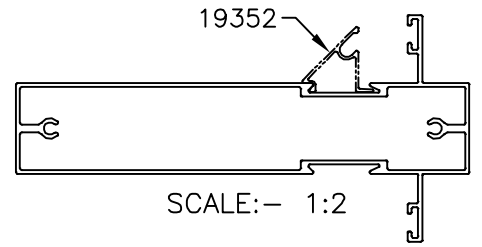

DETAIL OF "B"
SCALE:- 2:1

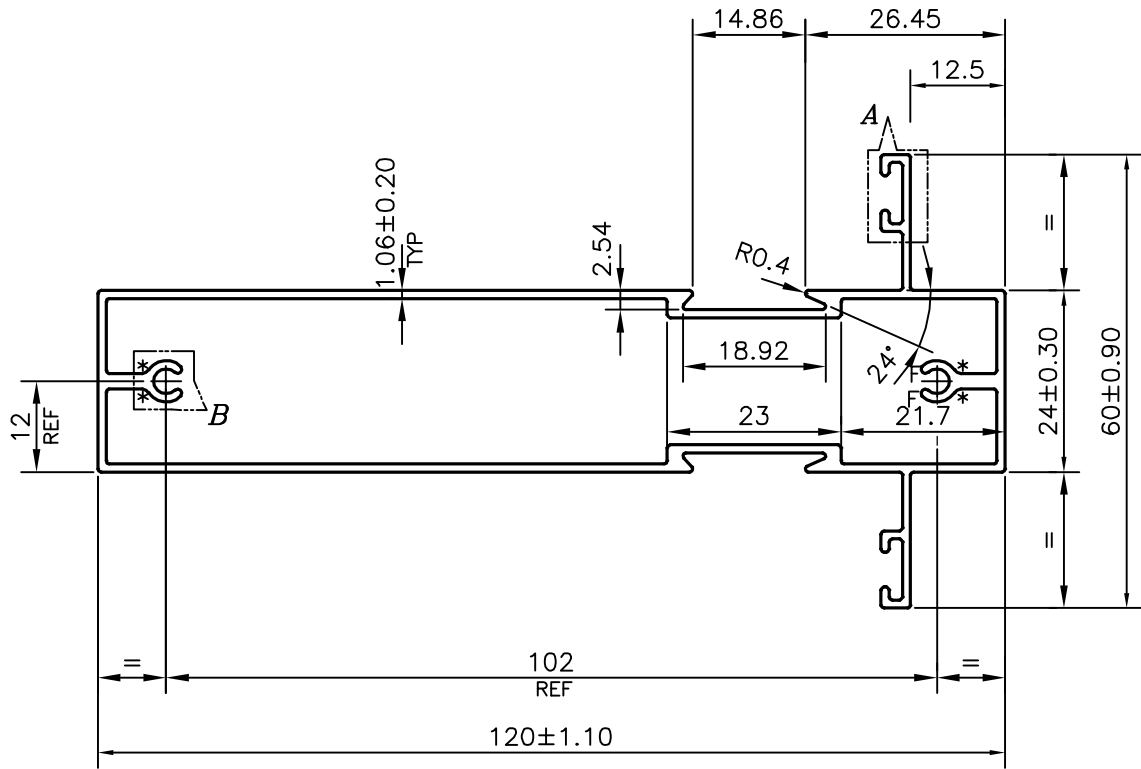
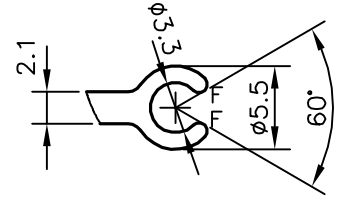

AVERAGE WEIGHT:-0.956 kg/m TO 1.401 kg/m

* = 1.0 RADIUS (4 PLACES)
F = FULL RADIUS (4 PLACES)

 SYMBOL OF QUALITY AN ISO 9001 COMPANY	JINDAL ALUMINIUM LTD. BANGALORE-560073 (INDIA)	NAME	DATE
		DRAWN	J.P.KAUSHIK 29-10-2020
		CHECKED	
		APPROVED	B.NATARAJA 10-11-2020
		SCALE	1:1
		AREA mm ²	436.639
		PERIMETER mm.	412.352
		WEIGHT kg/m	1.179
PARTY'S NAME	PRAYOSHA ENTERPRISES LTD., UGANDA	DRAWING No.	SECTION No.
PARTY'S DRAWING No.	MODIFIED OF 21434	P-21591-1	-
ALLOY & TEMPER	6063 T6	X2750	X2750
DESCRIPTION	WINDOW SECTION		