

P-21598

X2757

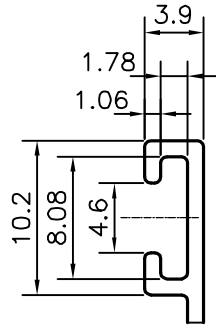

DETAIL OF "A"
SCALE:- 2:1

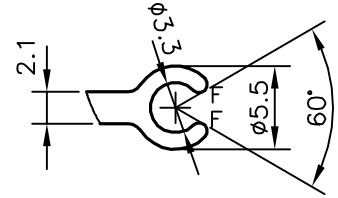
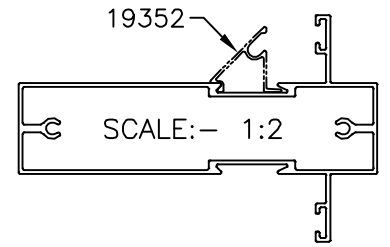

DETAIL OF "B"
SCALE:- 2:1

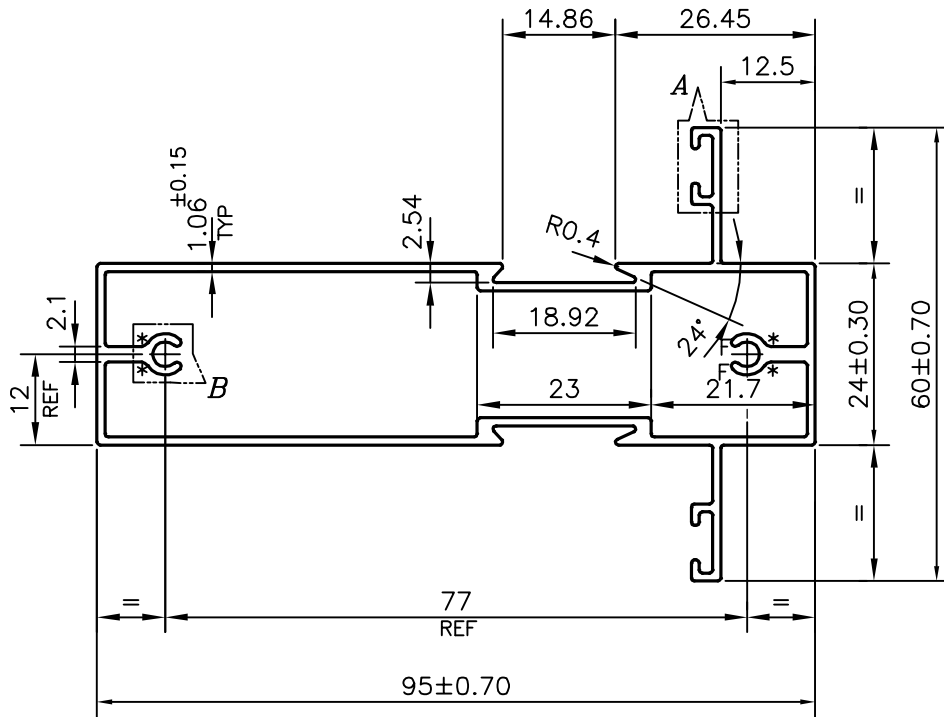

AVERAGE WEIGHT:-0.933 kg/m TO 1.139 kg/m

* = RADIUS 1.0 (4 PLACES)
F = FULL RADIUS (8 PLACES)



SYMBOL OF QUALITY
AN ISO 9001 COMPANY

JINDAL ALUMINIUM LTD.
BANGALORE-560073 (INDIA)

	NAME	DATE
DRAWN	J.P.KAUSHIK	03-10-2020
CHECKED		
APPROVED	B.NATARAJA	10-11-2020
SCALE		1:1
AREA mm ²		383.639
PERIMETER mm.		362.352
WEIGHT kg/m		1.036
DRAWING No.	SECTION No.	
P-21598	-	
X2757	X2757	

1. ALL DIMENSIONS ARE IN mm.
2. ROUND OFF ALL SHARP CORNERS WITH 0.40 mm.
3. TOLERANCES WILL BE AS PER BS:EN-755-9 UNLESS OTHERWISE SPECIFIED

PARTY'S NAME	PRAYOSHA ENTERPRISES LTD., UGANDA
PARTY'S DRAWING No.	MODIFIED OF 21464
ALLOY & TEMPER	6063 T6
DESCRIPTION	WINDOW SECTION