

P-21599

X2758

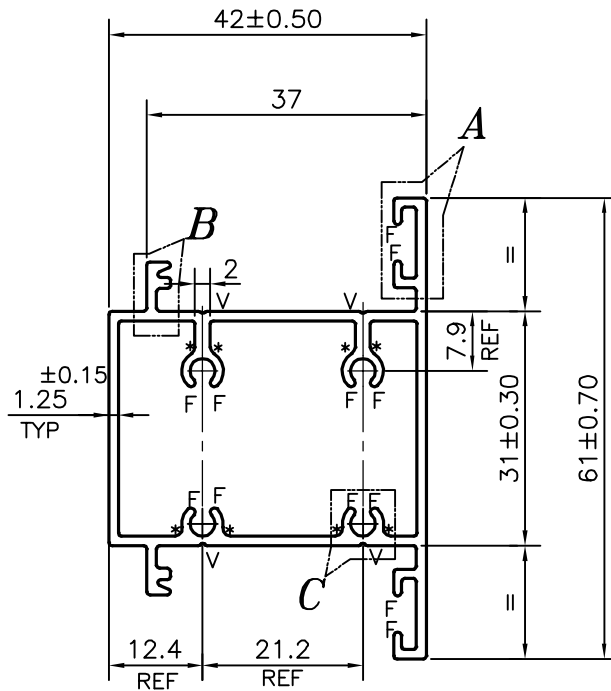
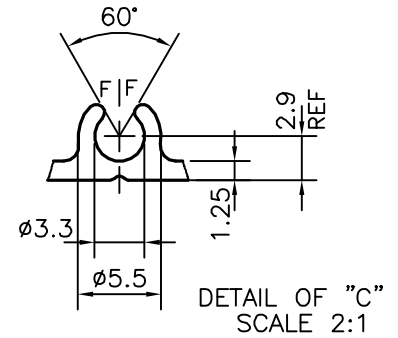
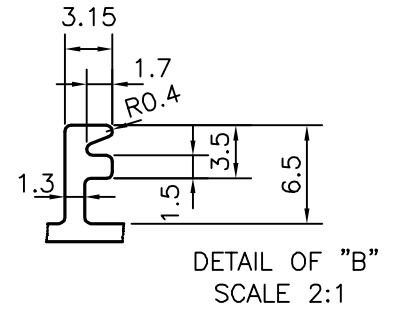
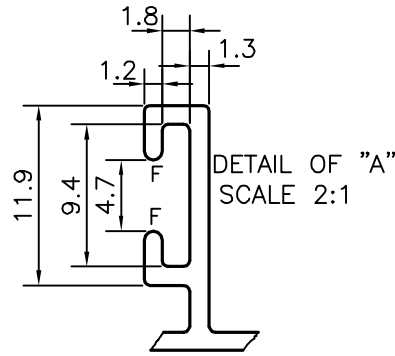

* = 1.0 RADIUS (8 PLACES)
 F = FULL RADIUS (12 PLACES)
 V = V GROOVE 0.3x90° (4 PLACES)

AVERAGE WEIGHT:-0.792 kg/m TO 0.968 kg/m



SYMBOL OF QUALITY
 AN ISO 9001 COMPANY

JINDAL ALUMINIUM LTD.
 BANGALORE-560073 (INDIA)

	NAME	DATE
DRAWN	J.P.KAUSHIK	03-10-2020
CHECKED		
APPROVED	B.NATARAJA	10-11-2020
SCALE		1:1
AREA mm ²		326.042
PERIMETER mm.		280.523
WEIGHT kg/m		0.880
DRAWING No.	SECTION No.	
P-21599	-	
X2758	X2758	

1. ALL DIMENSIONS ARE IN mm.
2. ROUND OFF ALL SHARP CORNERS WITH 0.40 mm.
3. TOLERANCES WILL BE AS PER BS:EN-755-9, UNLESS OTHERWISE SPECIFIED

PARTY'S NAME	PRAYOSHA ENTERPRISES LTD., UGANDA
PARTY'S DRAWING No.	MODIFIED OF 21624
ALLOY & TEMPER	6063 T6
DESCRIPTION	WINDOW SECTION