

P-21630-1

X2759

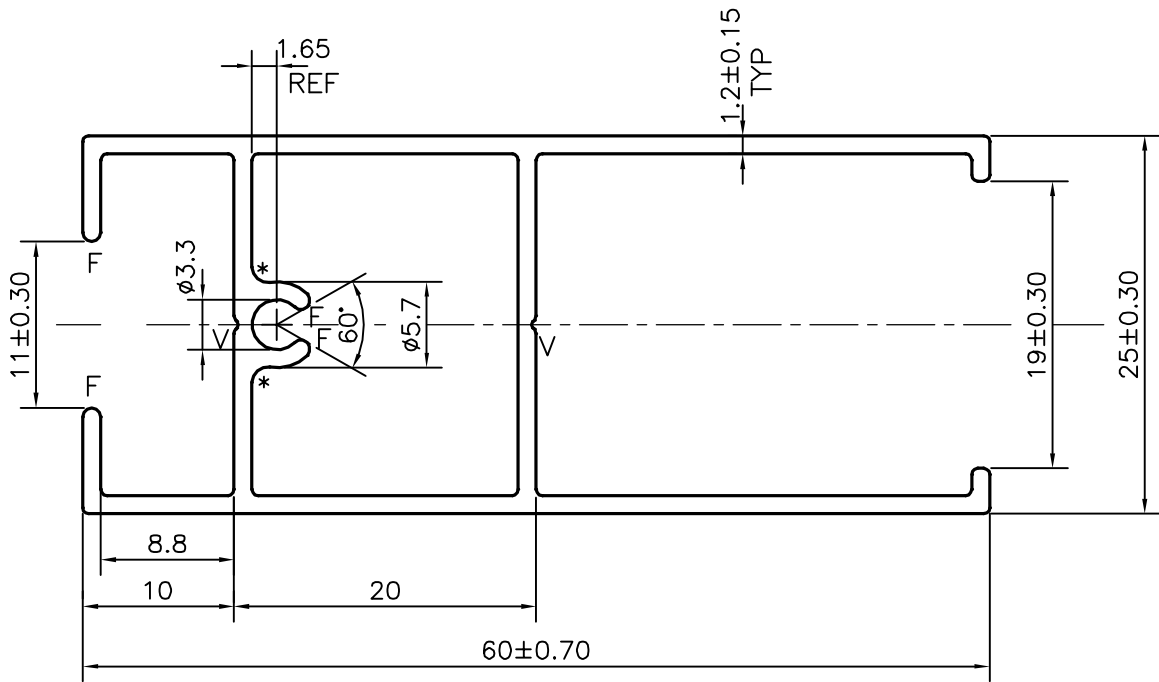
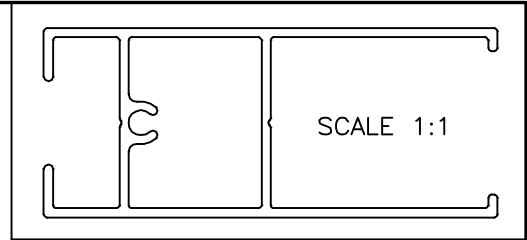

- \* = 1.0 RADIUS (2 PLACES)
- F = FULL RADIUS (4 PLACES)
- V = V GROOVE  $0.3 \times 90^\circ$  (2 PLACES)

AVERAGE WEIGHT:  $-0.553$  kg/m TO  $0.677$  kg/m



SYMBOL OF QUALITY  
AN ISO 9001 COMPANY

**JINDAL ALUMINIUM LTD.**  
BANGALORE-560073 (INDIA)

	NAME	DATE
DRAWN	J.P.KAUSHIK	29-10-2020
CHECKED		
APPROVED	B.NATARAJA	10-11-2020
SCALE		2:1
AREA mm <sup>2</sup>		226.718
PERIMETER mm.		277
WEIGHT kg/m		0.612
DRAWING No.		SECTION No.
P-21630-1		-
X2759		X2759

1. ALL DIMENSIONS ARE IN mm.
2. ROUND OFF ALL SHARP CORNERS WITH 0.40 mm.
3. TOLERANCES WILL BE AS PER BS:EN-755-9, UNLESS OTHERWISE SPECIFIED

PARTY'S NAME	PRAYOSHA ENTERPRISES LTD., UGANDA
PARTY'S DRAWING No.	MODIFIED OF 20639
ALLOY & TEMPER	6063 T6
DESCRIPTION	WINDOW SECTION