

P-21632-1

X2761

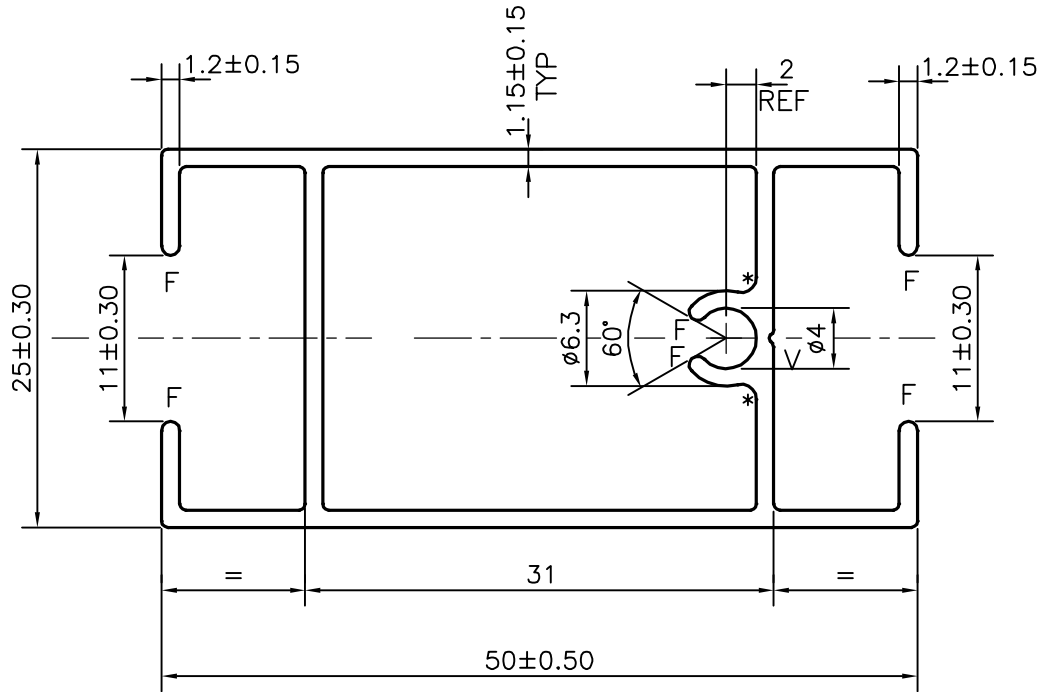
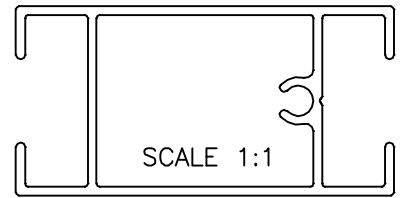

* = 1.0 RADIUS (2 PLACES)

F = FULL RADIUS (6 PLACES)

V = V GROOVE 0.3x90° (1 PLACE)

AVERAGE WEIGHT:-0.509 kg/m TO 0.623 kg/m



SYMBOL OF QUALITY
AN ISO 9001 COMPANY

JINDAL ALUMINIUM LTD.
BANGALORE-560073 (INDIA)

	NAME	DATE
DRAWN	J.P.KAUSHIK	29-10-2020
CHECKED		
APPROVED	B.NATARAJA	10-11-2020

1. ALL DIMENSIONS ARE IN mm.
2. ROUND OFF ALL SHARP CORNERS WITH 0.40 mm.
3. TOLERANCES WILL BE AS PER BS:EN-755-9, UNLESS OTHERWISE SPECIFIED

SCALE	2:1
AREA mm ²	207.087
PERIMETER mm.	230.868
WEIGHT kg/m	0.559

PARTY'S NAME	PRAYOSHA ENTERPRISES LTD., UGANDA	DRAWING No.	P-21632-1	SECTION No.	-
PARTY'S DRAWING No.	MODIFIED OF 20921		X2761		X2761
ALLOY & TEMPER	6063 T6				
DESCRIPTION	WINDOW SECTION				