

P-21633-1

X2762

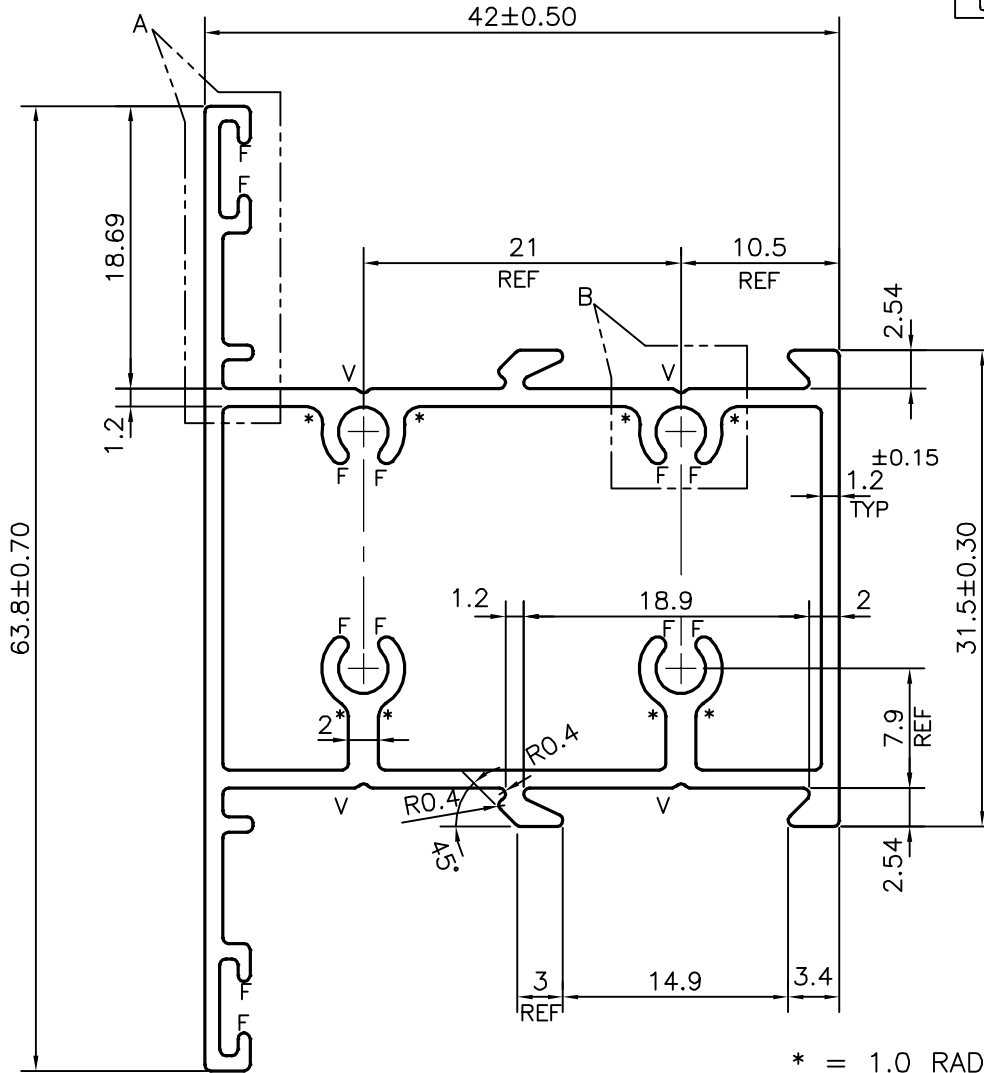
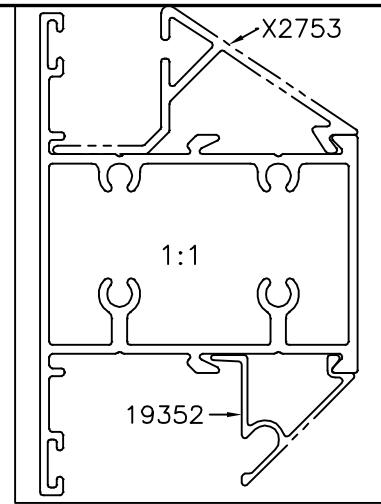
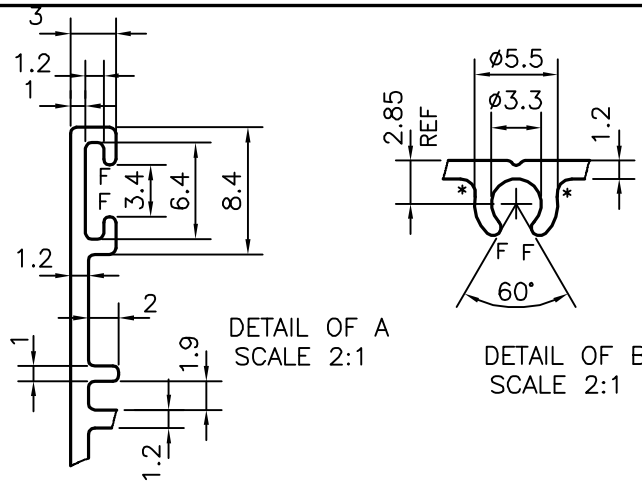

* = 1.0 RADIUS (8 PLACES)
 F = FULL RADIUS (12 PLACES)
 V = V GROOVE 0.3x90° (4 PLACES)

AVERAGE WEIGHT:-0.747 kg/m TO 0.913 kg/m



SYMBOL OF QUALITY
AN ISO 9001 COMPANY

JINDAL ALUMINIUM LTD.
BANGALORE-560073 (INDIA)

	NAME	DATE
DRAWN	J.P.KAUSHIK	31-10-2020
CHECKED		
APPROVED	B.NATARAJA	10-11-2020
SCALE		2:1
AREA mm ²		303.554
PERIMETER mm.		271.854
WEIGHT kg/m		0.820
DRAWING No.		SECTION No.
P-21633-1		-
X2762		X2762

1. ALL DIMENSIONS ARE IN mm.
2. ROUND OFF ALL SHARP CORNERS WITH 0.40 mm.
3. TOLERANCES WILL BE AS PER BS:EN-755-9 UNLESS OTHERWISE SPECIFIED

PARTY'S NAME	PRAYOSHA ENTERPRISES LTD., UGANDA
PARTY'S DRAWING No.	AS PER DRAWING
ALLOY & TEMPER	6063 T6
DESCRIPTION	WINDOW SECTION