

P-21536-2

X2766

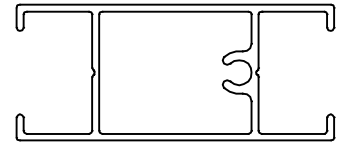

SCALE 1:1

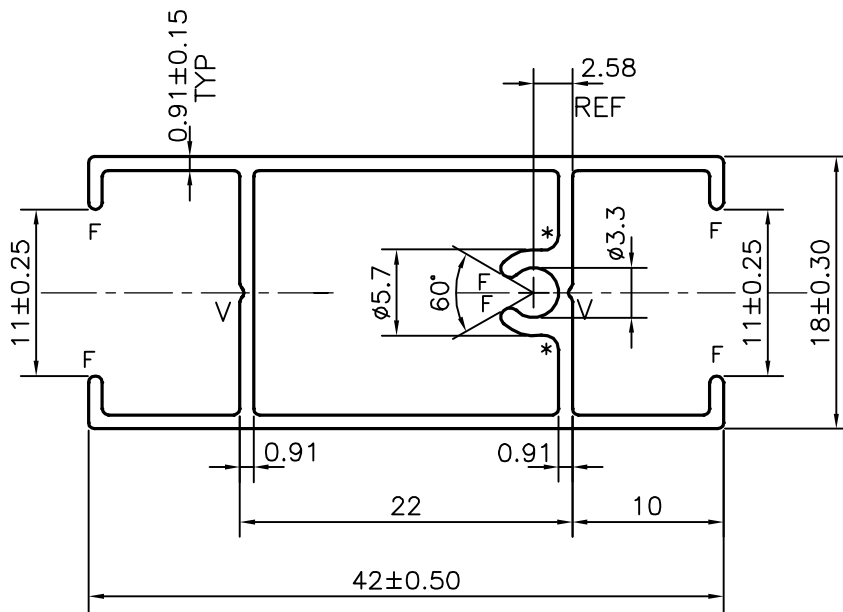

* = 1.0 RADIUS (2 PLACES)

F = FULL RADIUS (6 PLACES)

V = V GROOVE $0.3 \times 90^\circ$ (2 PLACES)

AVERAGE WEIGHT: -0.310 kg/m TO 0.378 kg/m



SYMBOL OF QUALITY
AN ISO 9001 COMPANY

JINDAL ALUMINIUM LTD.
BANGALORE-560073 (INDIA)

| | NAME | DATE |
|--------------------|-------------|-------------|
| DRAWN | J.P.KAUSHIK | 29-10-2020 |
| CHECKED | | |
| APPROVED | B.NATARAJA | 10-11-2020 |
| SCALE | | 2:1 |
| AREA mm^2 | | 125.645 |
| PERIMETER mm. | | 177.474 |
| WEIGHT kg/m | | 0.339 |
| DRAWING No. | | SECTION No. |
| P-21536-2 | | - |
| X2766 | | X2766 |
| | | |
| | | |

1. ALL DIMENSIONS ARE IN mm.
2. ROUND OFF ALL SHARP CORNERS WITH 0.40 mm.
3. TOLERANCES WILL BE AS PER BS:EN-755-9, UNLESS OTHERWISE SPECIFIED

| | |
|---------------------|-----------------------------------|
| PARTY'S NAME | PRAYOSHA ENTERPRISES LTD., UGANDA |
| PARTY'S DRAWING No. | LIGHTER OF 20920 |
| ALLOY & TEMPER | 6063 T6 |
| DESCRIPTION | WINDOW SECTION |