

P-21456

X2772

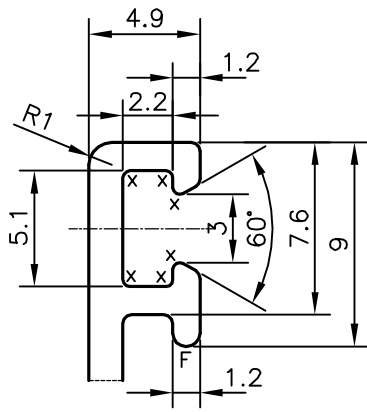

DETAIL OF "A"  
SCALE 3:1

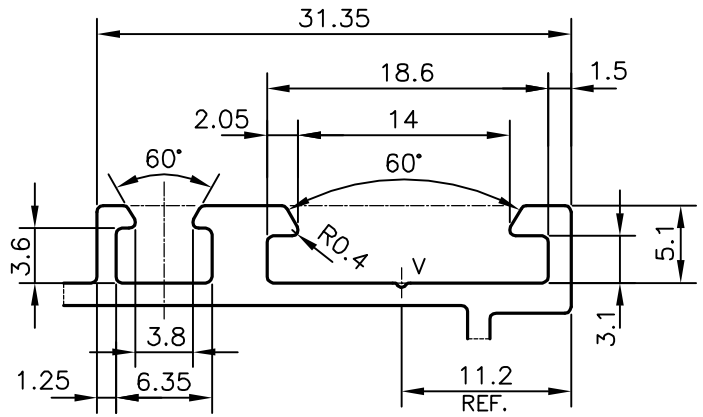

DETAIL OF "B"  
SCALE 2:1

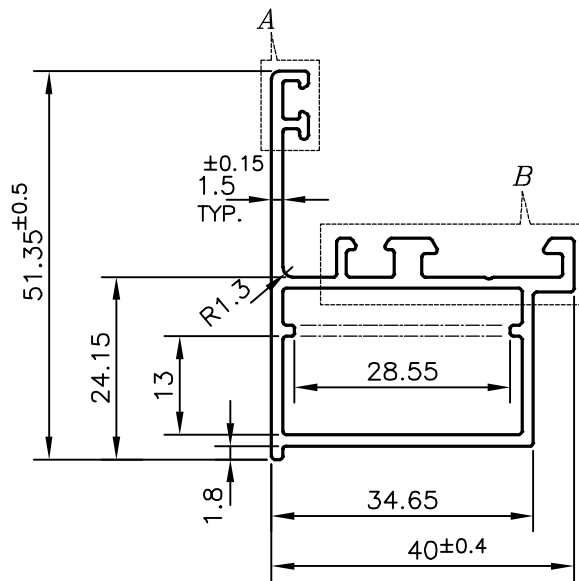

V = VEE GROOVE 0.3x90° (1 PLACE)  
F = FULL RADIUS (1 PLACE)  
X = RADIUS 0.3 mm. (6 PLACE)

APPROXIMATE WEIGHT RANGE :-0.673 kg/M TO 0.823 kg/M

TOLERANCES ON OVERALL WIDTHS & WIDTHS ACROSS FLATS OF BARS, & REGULAR SECTIONS

UPTO 6.40mm - ±0.20	UPTO 32.0mm - ±0.38	UPTO 120.0mm - ±0.85	1. STRAIGHTNESS=1.7mm/M 2. TWIST=1.7mm/M 3. ANGULARITY= ±2° 4. FLATNESS =0.007xWIDTH
UPTO 10.0mm - ±0.23	UPTO 50.0mm - ±0.46	UPTO 160.0mm - ±1.02	
UPTO 12.0mm - ±0.25	UPTO 60.0mm - ±0.53	UPTO 200.0mm - ±1.14	
UPTO 16.0mm - ±0.28	UPTO 80.0mm - ±0.69	UPTO 250.0mm - ±1.40	
UPTO 25.0mm - ±0.30	UPTO 100.0mm - ±0.75	UPTO 300.0mm - ±1.65	



SYMBOL OF QUALITY  
AN ISO 9001 COMPANY

**JINDAL ALUMINIUM LTD.**  
BANGALORE-560073 (INDIA)

	NAME	DATE
DRAWN	PARVESH	12-09-2020
CHECKED		
APPROVED	B.NATARAJA	09-12-2020
SCALE		1:1
AREA mm <sup>2</sup>		276.988
PERIMETER mm.		238.92
WEIGHT kg/m		0.748
DRAWING No.	SECTION No.	
P-21456	-	
X2772	X2772	

- ALL DIMENSIONS ARE IN mm.
- ROUND OFF ALL SHARP CORNERS WITH 0.40 mm.
- TOLERANCES WILL BE AS PER,IS:6477-1983 UNLESS OTHERWISE SPECIFIED

PARTY'S NAME	HARI ALUMINIUM, AHMEDABAD
PARTY'S DRAWING No.	AS PER AUTOCAD DRAWING
ALLOY & TEMPER	6063 T6
DESCRIPTION	WINDOW SECTION