

P-22132

X2919

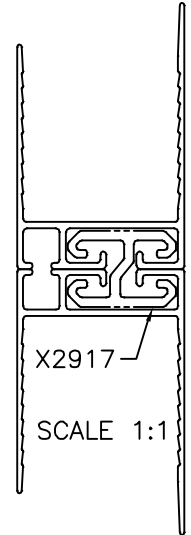
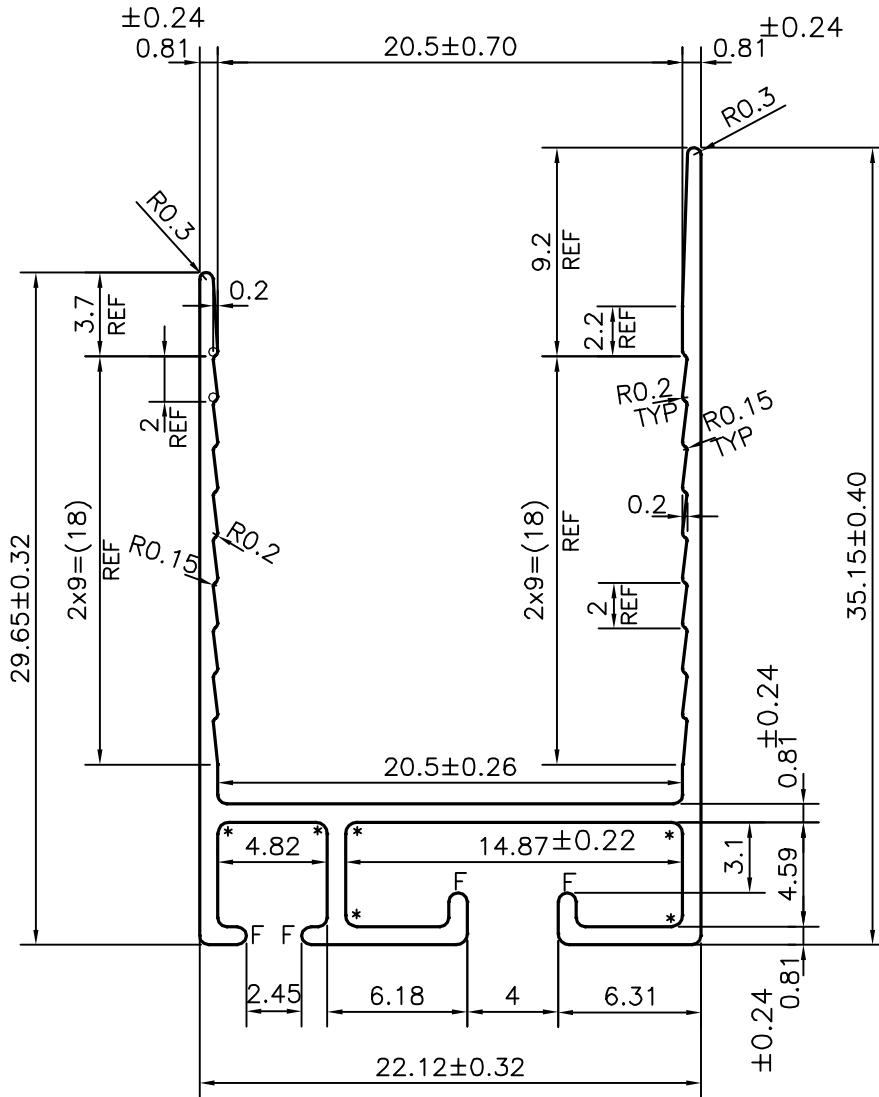
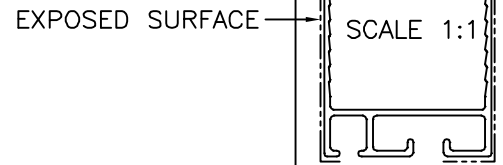

* = RADIUS 0.5 mm. (6 PLACES)

F = FULL RADIUS (4 PLACES)

APPROXIMATE WEIGHT RANGE - 0.199 - 0.243 kg/m

 SYMBOL OF QUALITY AN ISO 9001 COMPANY	JINDAL ALUMINIUM LTD. BANGALORE-560073 (INDIA)	NAME	DATE
		DRAWN	J.P.KAUSHIK 06-02-2021
		CHECKED	
		APPROVED	B.NATARAJA 24-02-2021
		SCALE	3:1
		AREA mm ²	81.839
		PERIMETER mm.	211.695
		WEIGHT kg/m	0.221
PARTY'S NAME	ARABIAN AIR CONDITIONING MANUFACTURING CO., DOHA-QATAR	DRAWING No.	SECTION No.
PARTY'S DRAWING No.	2938	P-22132	-
ALLOY & TEMPER	6063 T6	X2919	X2919
DESCRIPTION	INVISIBLE FLANGE SECTION		