

P-5158-3

X356

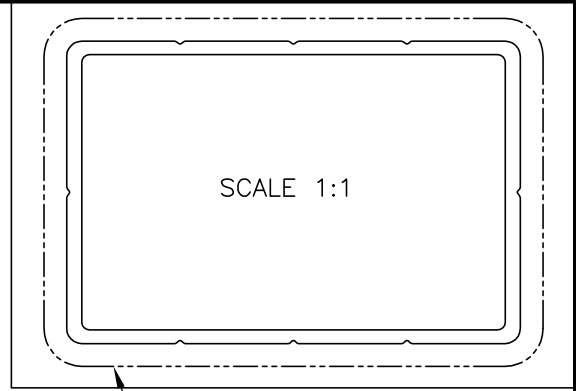

EXPOSED SURFACE BETTER FINISH REQUIRED

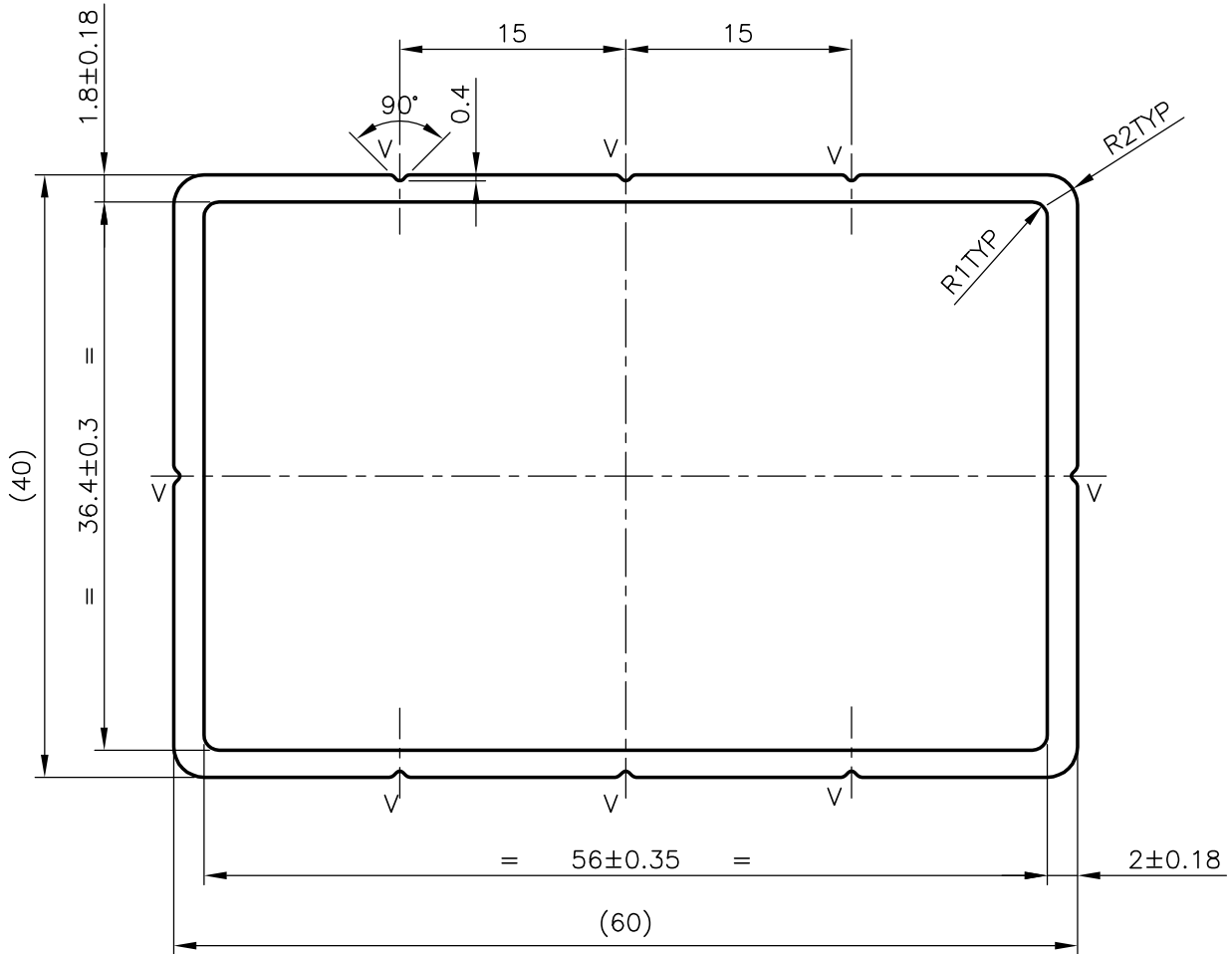

V = VEE GROOVE 0.40x90° (8 PLACES)



SYMBOL OF QUALITY
AN ISO 9001 COMPANY

JINDAL ALUMINIUM LTD.
BANGALORE-560073 (INDIA)

	NAME	DATE
DRAWN	RAGHAVENDRA	10-12-2004
CHECKED		
APPROVED		

- ALL DIMENSIONS ARE IN mm.
- ROUND OFF ALL SHARP CORNERS WITH 0.40 mm.
- TOLERANCES WILL BE AS PER DIN:17615 PART-3 UNLESS OTHERWISE SPECIFIED

SCALE	2:1
AREA mm ²	356.925
PERIMETER mm.	198.735
WEIGHT kg/m	0.964

PARTY'S NAME	MAYFAIR IMPORTS, AUSTRALIA
PARTY'S DRAWING No.	AS PER SKETCH
ALLOY & TEMPER	6005 T6
DESCRIPTION	MISC. TUBE

DRAWING No.	SECTION No.
P-5158-3	-
X356	X356