

P-5976

X461

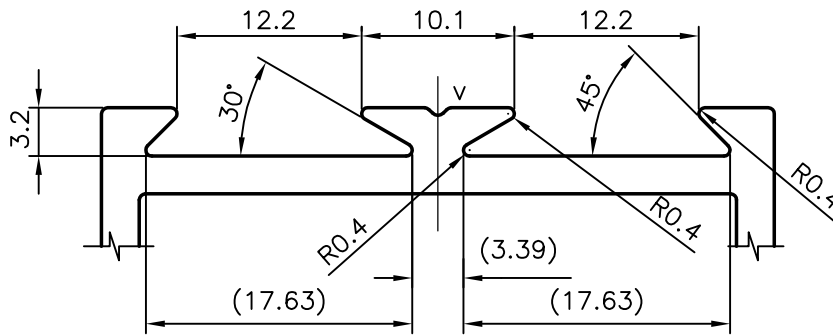

DETAIL-A

SCALE:-2:1

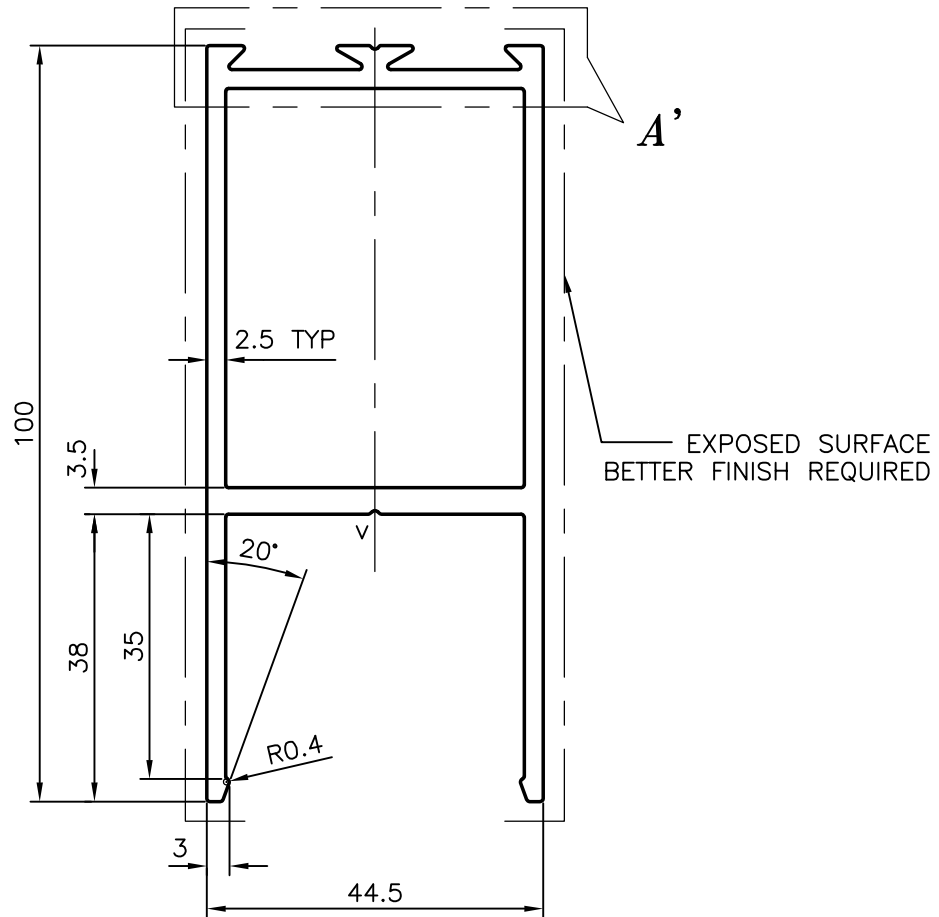

V = VEE GROOVE 0.5x90°xR0.5 (2 PLACES)

GENERAL WALL THICKNESS = 2.5 mm



SYMBOL OF QUALITY
AN ISO 9001 COMPANY

JINDAL ALUMINIUM LTD.
BANGALORE-560073 (INDIA)

	NAME	DATE
DRAWN	MALINGAPPA	03-12-2005
CHECKED		
APPROVED		
SCALE	1:1	
AREA mm ²	767.733	
PERIMETER mm.	392.023	
WEIGHT kg/m	2.073	
DRAWING No.	SECTION No.	
P-5976	-	
X461	X461	

1. ALL DIMENSIONS ARE IN mm.
2. ROUND OFF ALL SHARP CORNERS WITH 0.40 mm.
3. TOLERANCES WILL BE AS PER BS:1474-1987 UNLESS OTHERWISE SPECIFIED

PARTY'S NAME	J. CAPITAL SHOPFRONT LTD., U.K.
PARTY'S DRAWING No.	AS PER SAMPLE (GS-18)
ALLOY & TEMPER	6063 T6
DESCRIPTION	DOOR SECTION (BOTTOM)