

P-5978

X462

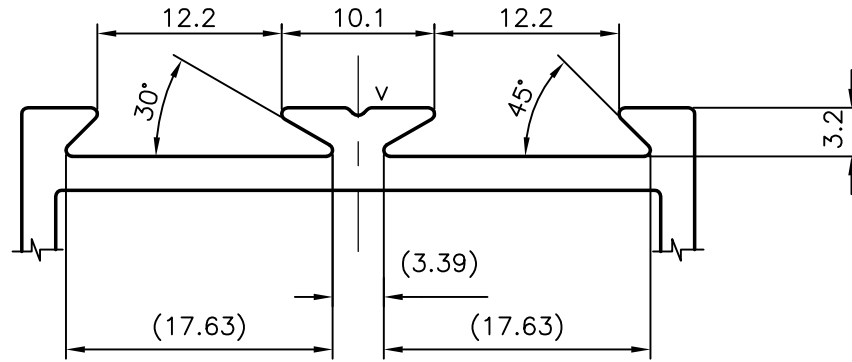

DETAIL-A
SCALE: -2:1

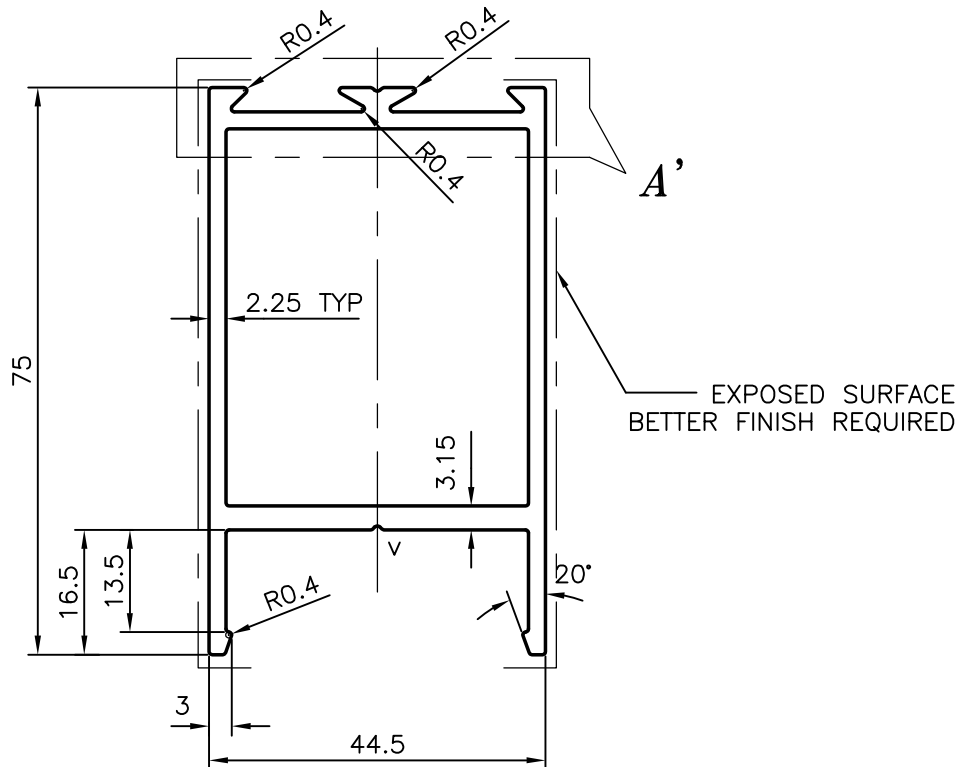

V = VEE GROOVE 0.5x90°xR0.5 (2 PLACES)
GENERAL WALL THICKNESS = 2.25 mm



SYMBOL OF QUALITY
AN ISO 9001 COMPANY

JINDAL ALUMINIUM LTD.
BANGALORE-560073 (INDIA)

	NAME	DATE
DRAWN	MALINGAPPA	03-12-2005
CHECKED		
APPROVED		
SCALE		1:1
AREA mm ²		587.361
PERIMETER mm.		299.924
WEIGHT kg/m		1.586
DRAWING No.	SECTION No.	
P-5978	-	
X462	X462	

1. ALL DIMENSIONS ARE IN mm.
2. ROUND OFF ALL SHARP CORNERS WITH 0.40 mm.
3. TOLERANCES WILL BE AS PER BS:1474-1987 UNLESS OTHERWISE SPECIFIED

PARTY'S NAME	J. CAPITAL SHOPFRONT LTD., U.K.
PARTY'S DRAWING No.	AS PER SAMPLE (GS-17)
ALLOY & TEMPER	6063 T6
DESCRIPTION	DOOR SECTION (BOTTOM)