

P-6010

X471

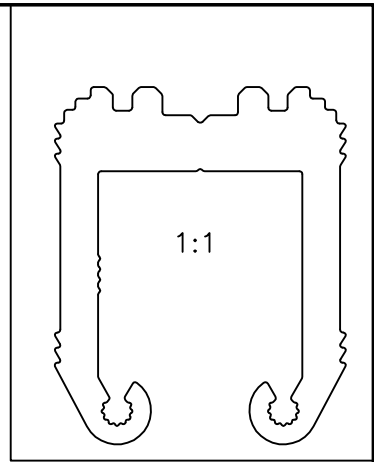

**DETAIL-A**  
SCALE:-3:1

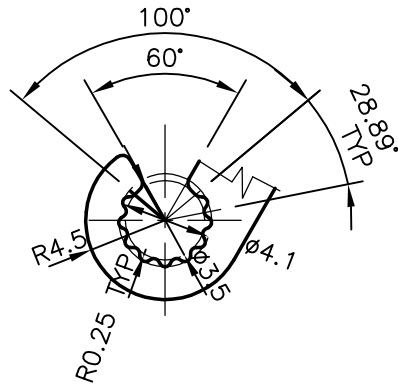
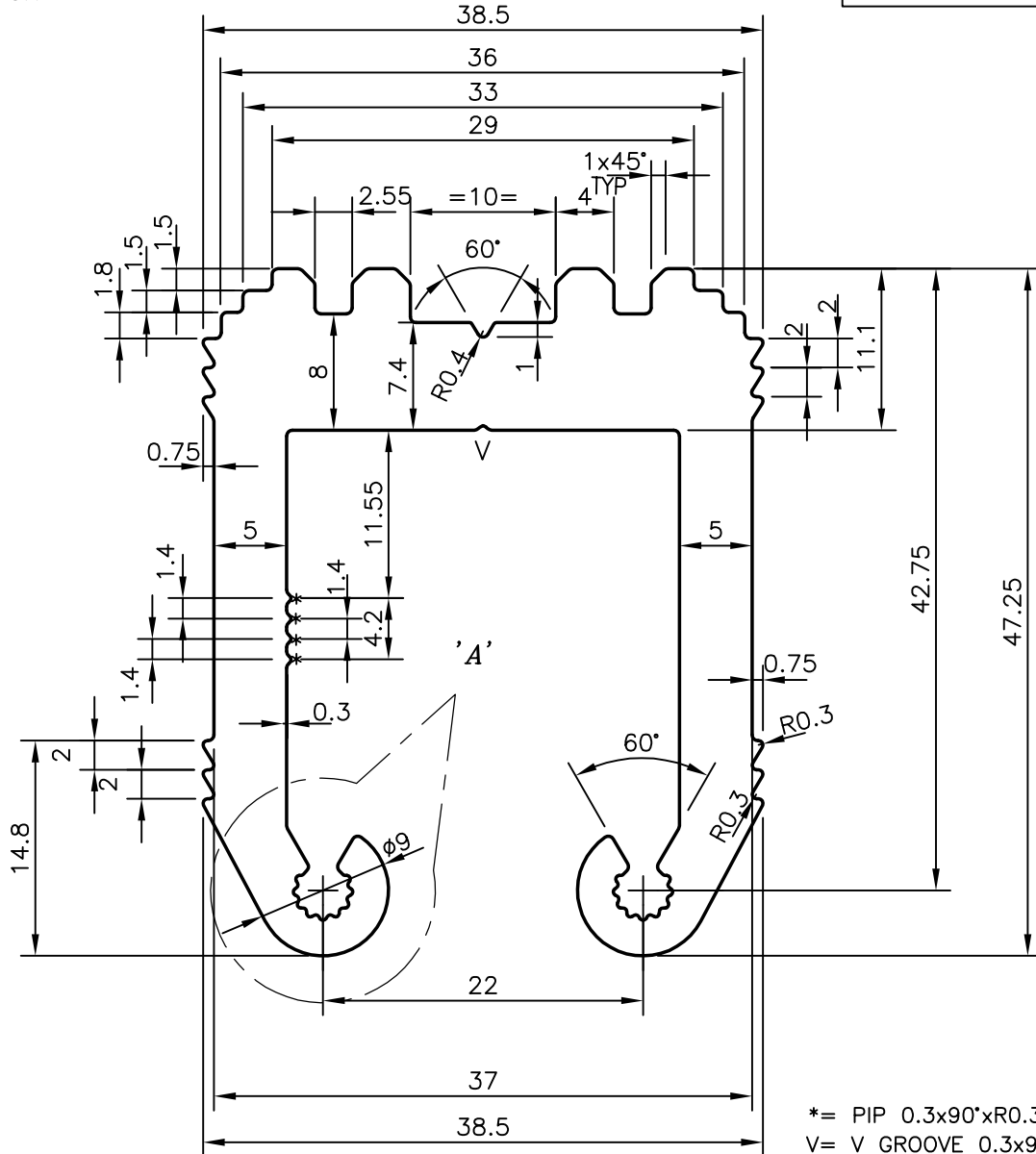

\*= PIP 0.3x90°xR0.3 (4 PLACES)  
V= V GROOVE 0.3x90°



SYMBOL OF QUALITY  
AN ISO 9001 COMPANY

**JINDAL ALUMINIUM LTD.**  
BANGALORE-560073 (INDIA)

	NAME	DATE
DRAWN	J.P.KAUSHIK	05-12-2005
CHECKED		
APPROVED		

1. ALL DIMENSIONS ARE IN mm.
2. ROUND OFF ALL SHARP CORNERS WITH 0.40 mm.
3. TOLERANCES WILL BE AS PER BS:1474-1987 UNLESS OTHERWISE SPECIFIED

SCALE	2:1
AREA mm <sup>2</sup>	727.142
PERIMETER mm.	301.545
WEIGHT kg/m	1.963

PARTY'S NAME	J.CAPITAL SHOPFRONT LTD.,U.K
PARTY'S DRAWING No.	AS PER SAMPLE
ALLOY & TEMPER	6063 T6
DESCRIPTION	-

DRAWING No.	SECTION No.
P-6010	-
X471	X471