

P-6022

X475

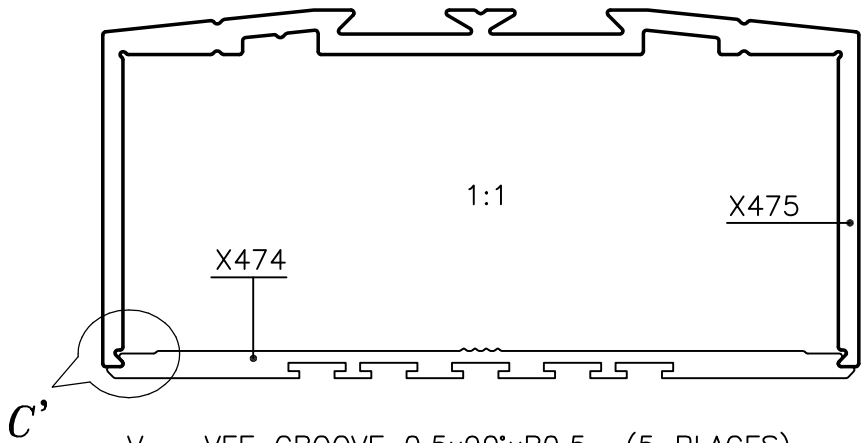
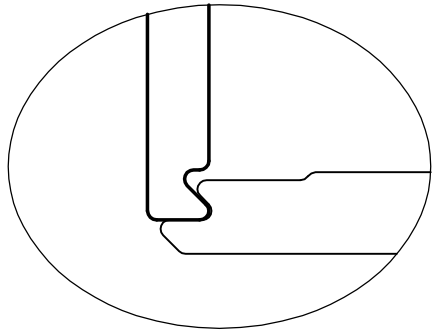

V = VEE GROOVE 0.5x90°xR0.5 (5 PLACES)

GENERAL WALL THICKNESS = 2.7 mm

P = PIP 0.5x90°xR0.5 (1 PLACES)

DETAIL-C

SCALE:-3:1

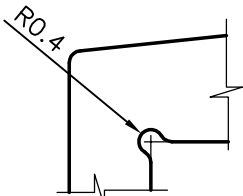
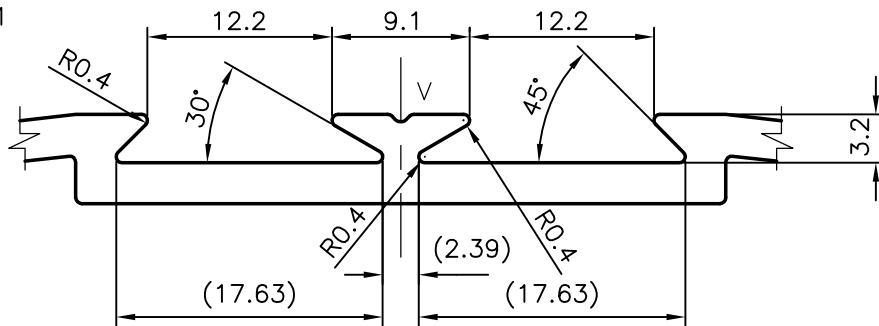

DETAIL-B

SCALE:-4:1

DETAIL-A

SCALE:-2:1

EXPOSED SURFACE
BETTER FINISH REQUIRED

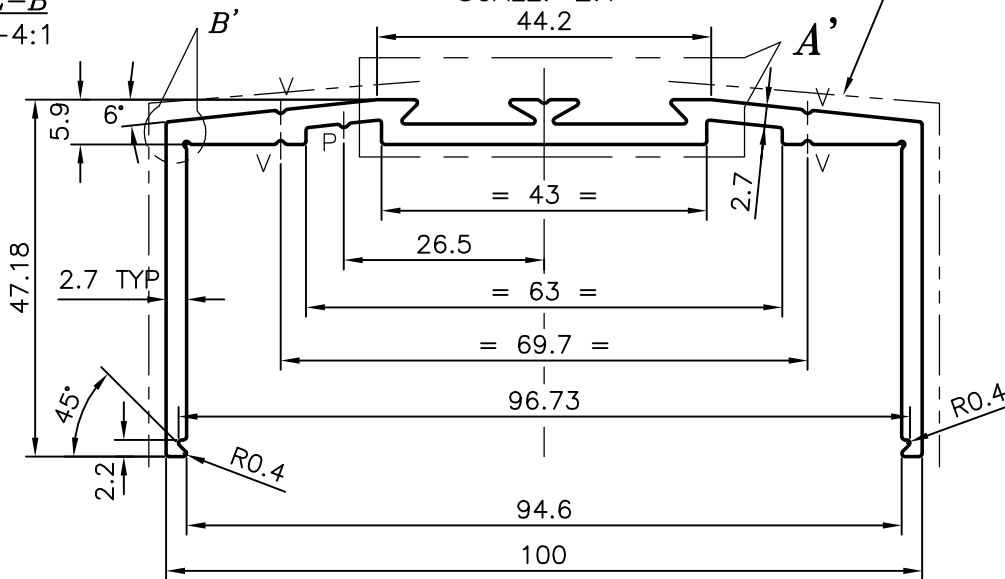

SYMBOL OF QUALITY
AN ISO 9001 COMPANY

JINDAL ALUMINIUM LTD.
BANGALORE-560073 (INDIA)

	NAME	DATE
DRAWN	MALINGAPPA	04-12-2005
CHECKED		
APPROVED		

1. ALL DIMENSIONS ARE IN mm.
2. ROUND OFF ALL SHARP CORNERS WITH 0.40 mm.
3. TOLERANCES WILL BE AS PER BS:1474-1987 UNLESS OTHERWISE SPECIFIED

SCALE	1:1
AREA mm ²	576.036
PERIMETER mm.	413.765
WEIGHT kg/m	1.555

PARTY'S NAME	J. CAPITAL SHOPFRONT LTD., U.K.
PARTY'S DRAWING No.	AS PER SAMPLE
ALLOY & TEMPER	6063 T6
DESCRIPTION	MISC. SECTION

DRAWING No.	SECTION No.
P-6022	-
X475	X475