

P-6023

X476

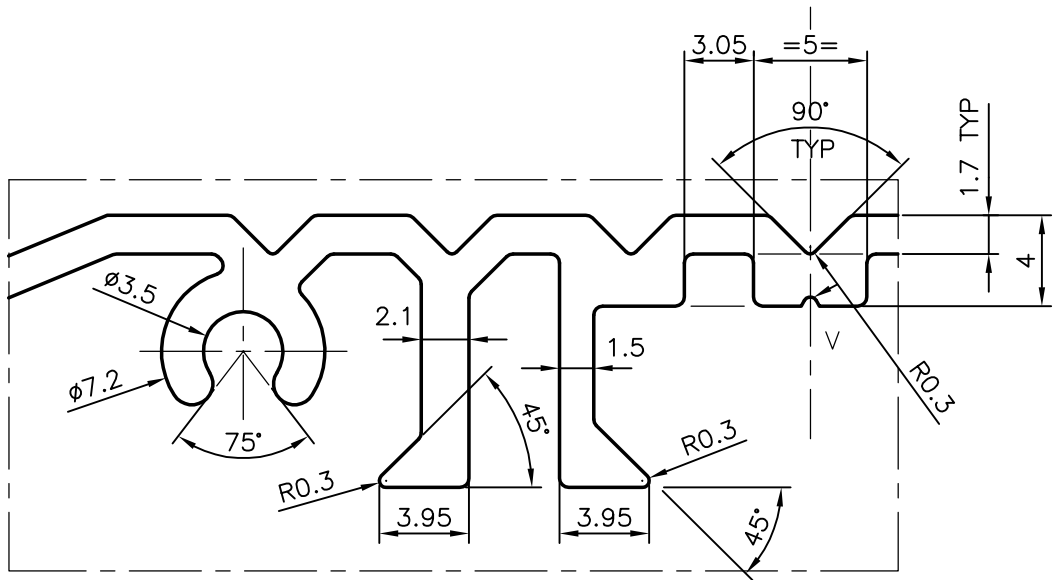

DETAIL-A
SCALE: -3:1

V = VEE GROOVE 0.4x60°xR0.3 (1 PLACE)
GENERAL WALL THICKNESS = 1.7 mm

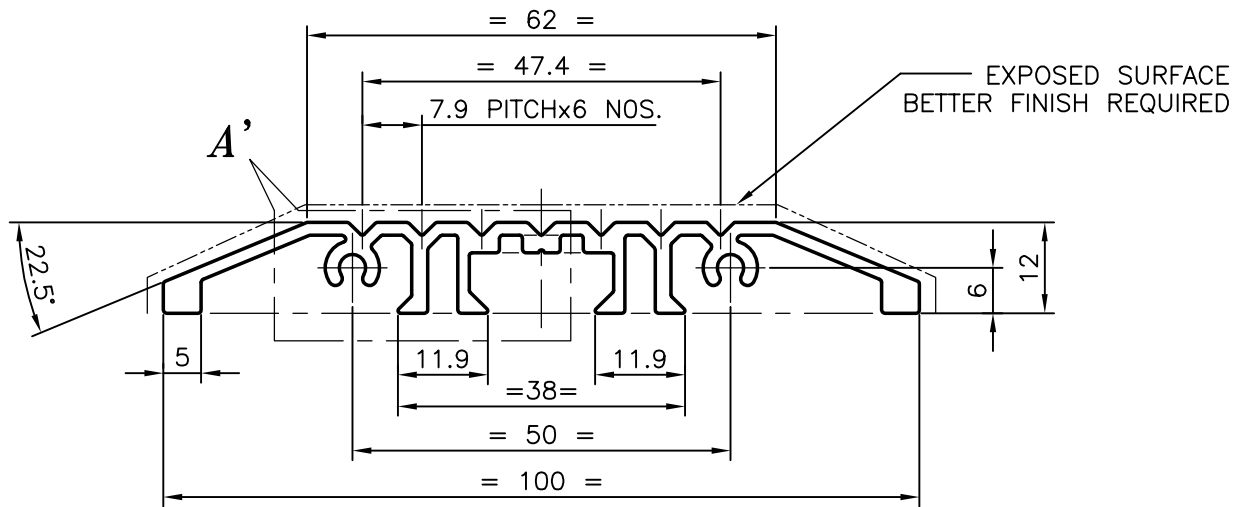

SYMBOL OF QUALITY
AN ISO 9001 COMPANY

JINDAL ALUMINIUM LTD.
BANGALORE-560073 (INDIA)

	NAME	DATE
DRAWN	MALINGAPPA	04-12-2005
CHECKED		
APPROVED		
SCALE		1:1
AREA mm ²		362.21
PERIMETER mm.		369.63
WEIGHT kg/m		0.979
DRAWING No.	SECTION No.	
P-6023	-	
X476	X476	

1. ALL DIMENSIONS ARE IN mm.
2. ROUND OFF ALL SHARP CORNERS WITH 0.40 mm.
3. TOLERANCES WILL BE AS PER BS:1474-1987 UNLESS OTHERWISE SPECIFIED

PARTY'S NAME	J. CAPITAL SHOPFRONT LTD., U.K.
PARTY'S DRAWING No.	AS PER SAMPLE
ALLOY & TEMPER	6063 T6
DESCRIPTION	MISC. SECTION