

P-6055

X483

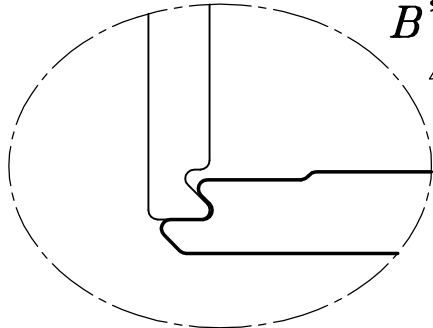

DETAIL-B
SCALE:-3:1

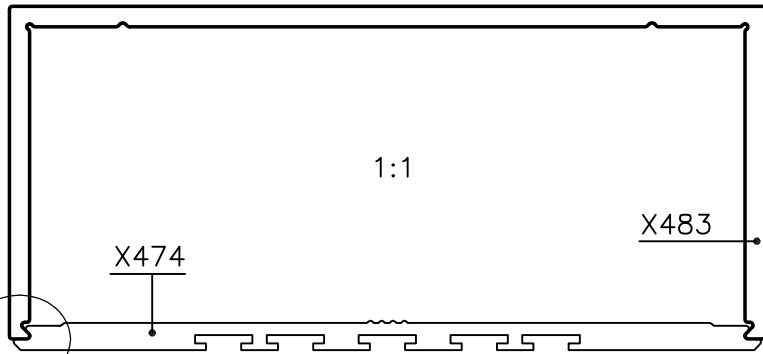
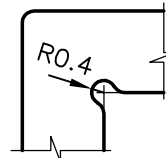

DETAIL-A
SCALE:4:1

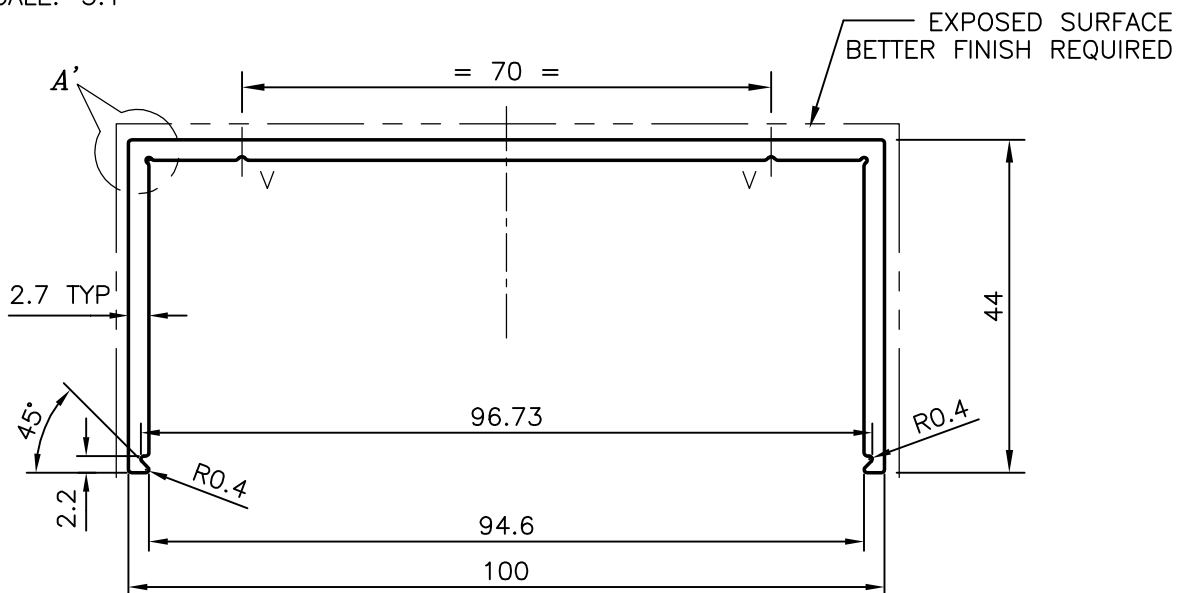

V = VEE GROOVE 0.5x90°xR0.5 (2 PLACES)
GENERAL WALL THICKNESS = 2.7 mm



SYMBOL OF QUALITY
AN ISO 9001 COMPANY

JINDAL ALUMINIUM LTD.
BANGALORE-560073 (INDIA)

	NAME	DATE
DRAWN	MALINGAPPA	17-12-2005
CHECKED		
APPROVED		
SCALE	1:1	
AREA mm ²	488.751	
PERIMETER mm.	374.347	
WEIGHT kg/m	1.320	
DRAWING No.	SECTION No.	
P-6055	-	
X483	X483	

1. ALL DIMENSIONS ARE IN mm.
2. ROUND OFF ALL SHARP CORNERS WITH 0.40 mm.
3. TOLERANCES WILL BE AS PER BS:1474-1987 UNLESS OTHERWISE SPECIFIED

PARTY'S NAME	J.CAPITAL SHOPFRONT LTD.,U.K
PARTY'S DRAWING No.	AS PER SAMPLE
ALLOY & TEMPER	6063 T6
DESCRIPTION	MISC. CHANNEL