

P-6143

X507

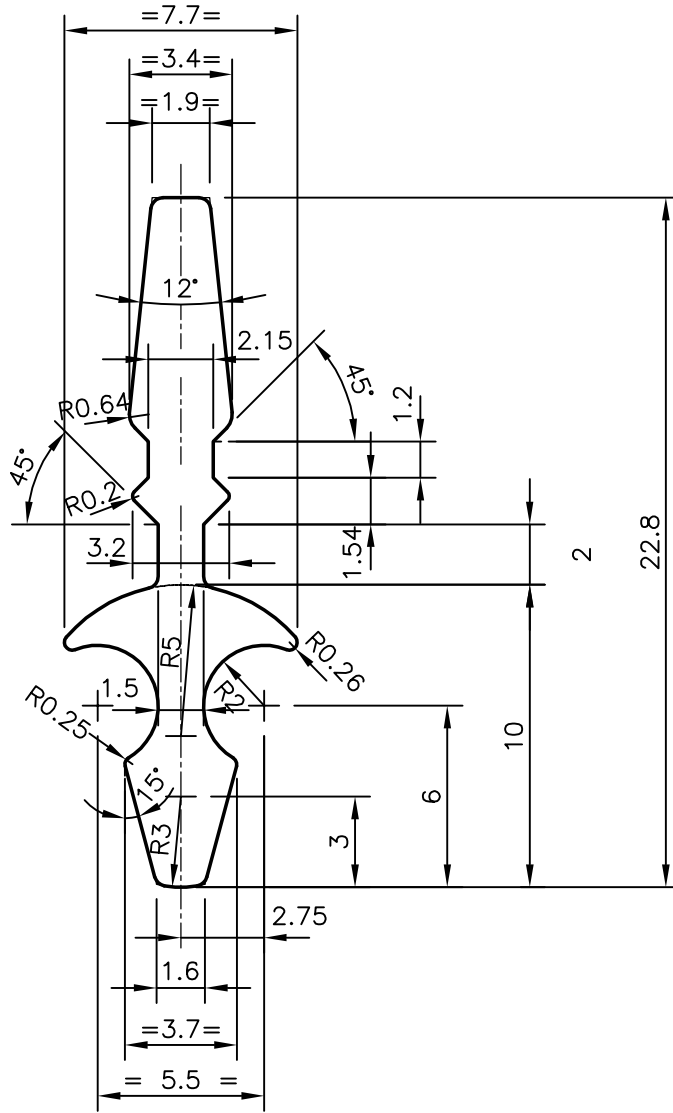
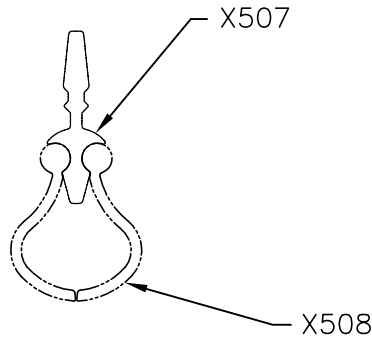
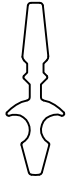

SYMBOL OF QUALITY  
AN ISO 9001 COMPANY

**JINDAL ALUMINIUM LTD.**  
BANGALORE-560073 (INDIA)

	NAME	DATE
DRAWN	J.P.KAUSHIK	18-01-2006
CHECKED		
APPROVED		
SCALE		4:1
AREA mm <sup>2</sup>		62.144
PERIMETER mm.		59.473
WEIGHT kg/m		0.168
DRAWING No.	SECTION No.	
P-6143	-	
X507	X507	

1. ALL DIMENSIONS ARE IN mm.
2. ROUND OFF ALL SHARP CORNERS WITH 0.40 mm.
3. TOLERANCES WILL BE AS PER BS:1474-1987 UNLESS OTHERWISE SPECIFIED

PARTY'S NAME	AIR MASTER EQUIPMENTS EMIRATES LLC,
PARTY'S DRAWING No.	QUOT REF 5/01082
ALLOY & TEMPER	6063 T5
DESCRIPTION	AIR GRILL SECTION