

P-6183

X518

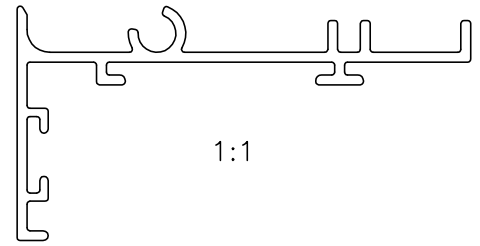

1:1

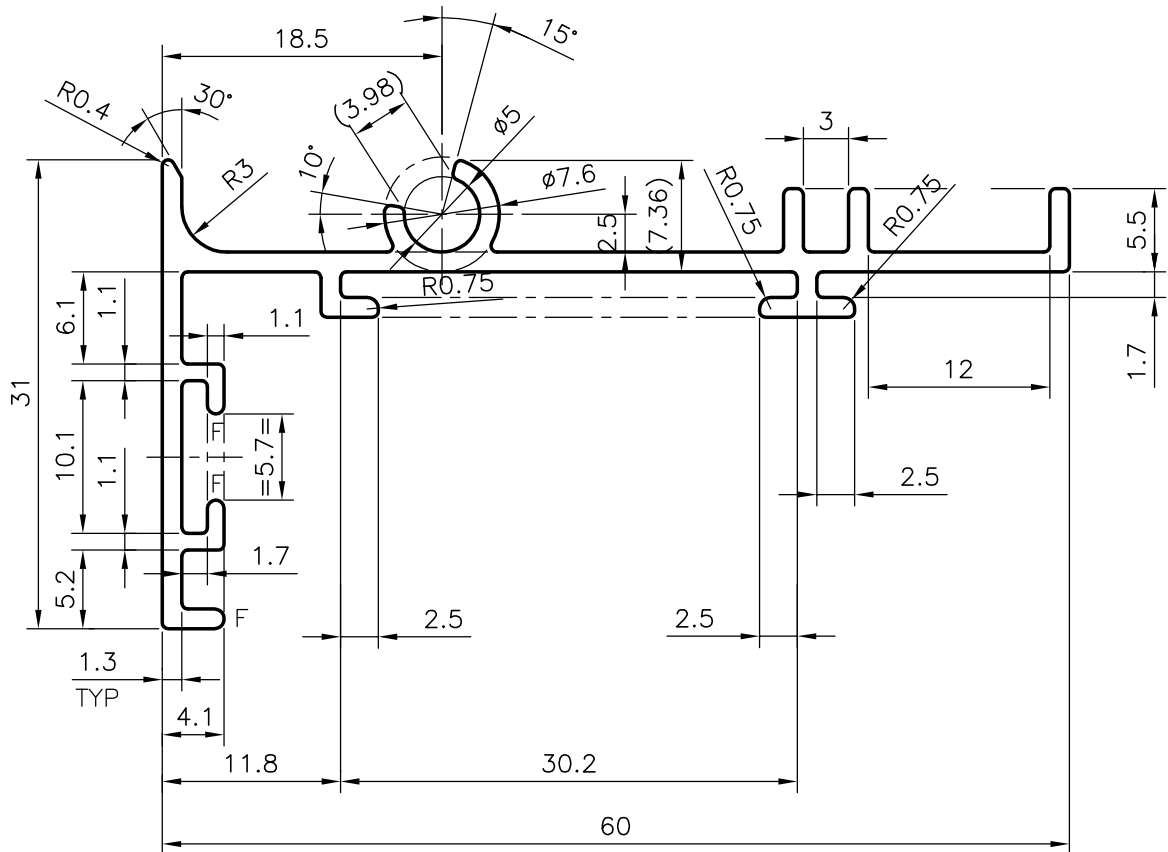

GENERAL WALL THICKNESS = 1.3 mm

F = FULL TADIUS (3 PLACES)



SYMBOL OF QUALITY  
AN ISO 9001 COMPANY

**JINDAL ALUMINIUM LTD.**  
BANGALORE-560073 (INDIA)

|          | NAME         | DATE       |
|----------|--------------|------------|
| DRAWN    | Mahalingappa | 08-02-2006 |
| CHECKED  |              |            |
| APPROVED |              |            |

1. ALL DIMENSIONS ARE IN mm.
2. ROUND OFF ALL SHARP CORNERS WITH 0.40 mm.
3. TOLERANCES WILL BE AS PER BS:1474-1987 UNLESS OTHERWISE SPECIFIED

|                      |         |
|----------------------|---------|
| SCALE                | 2:1     |
| AREA mm <sup>2</sup> | 179.978 |
| PERIMETER mm.        | 267     |
| WEIGHT kg/m          | 0.486   |

PARTY'S NAME AIR MASTER EQUIPMENTS EMIRATES L.L.C.

DRAWING No. SECTION No.

PARTY'S DRAWING No. 11706/R/00

P-6183  
X518

ALLOY & TEMPER 6063 T6

DESCRIPTION AIR GRILL SECTION