

P-6184

X520

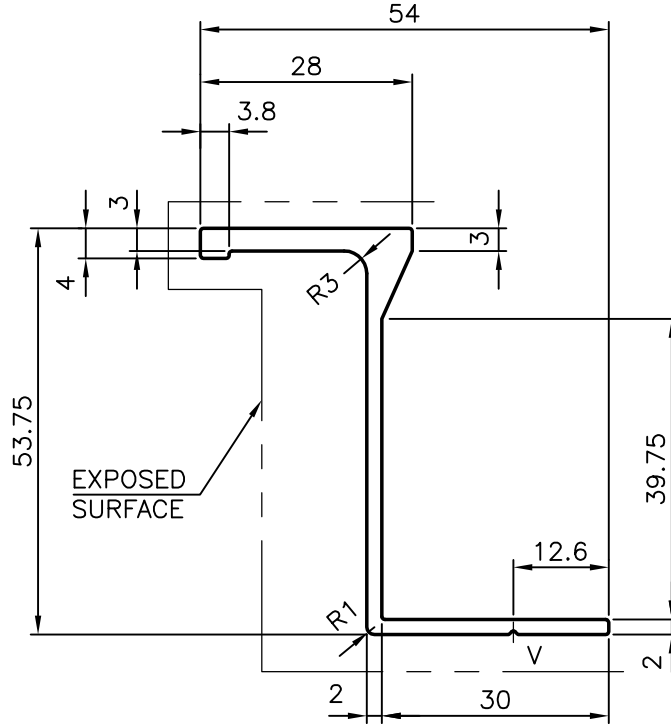

V = 0.5x90°xR0.3 (1 PLACE)



SYMBOL OF QUALITY
AN ISO 9001 COMPANY

JINDAL ALUMINIUM LTD.
BANGALORE-560073 (INDIA)

	NAME	DATE
DRAWN	MALINGAPPA	09-02-2006
CHECKED		
APPROVED		
SCALE		1:1
AREA mm ²		268.502
PERIMETER mm.		219.613
WEIGHT kg/m		0.725
DRAWING No.		SECTION No.
P-6184		-
X520		X520

1. ALL DIMENSIONS ARE IN mm.
2. ROUND OFF ALL SHARP CORNERS WITH 0.40 mm.
3. TOLERANCES WILL BE AS PER COMMERCIAL UNLESS OTHERWISE SPECIFIED

PARTY'S NAME	PROSOURCE SOLUTIONS INC. CANADA
PARTY'S DRAWING No.	AS PER DRAWING
ALLOY & TEMPER	6063 T5
DESCRIPTION	MISC. SECTION