

P-6501

17633

X597

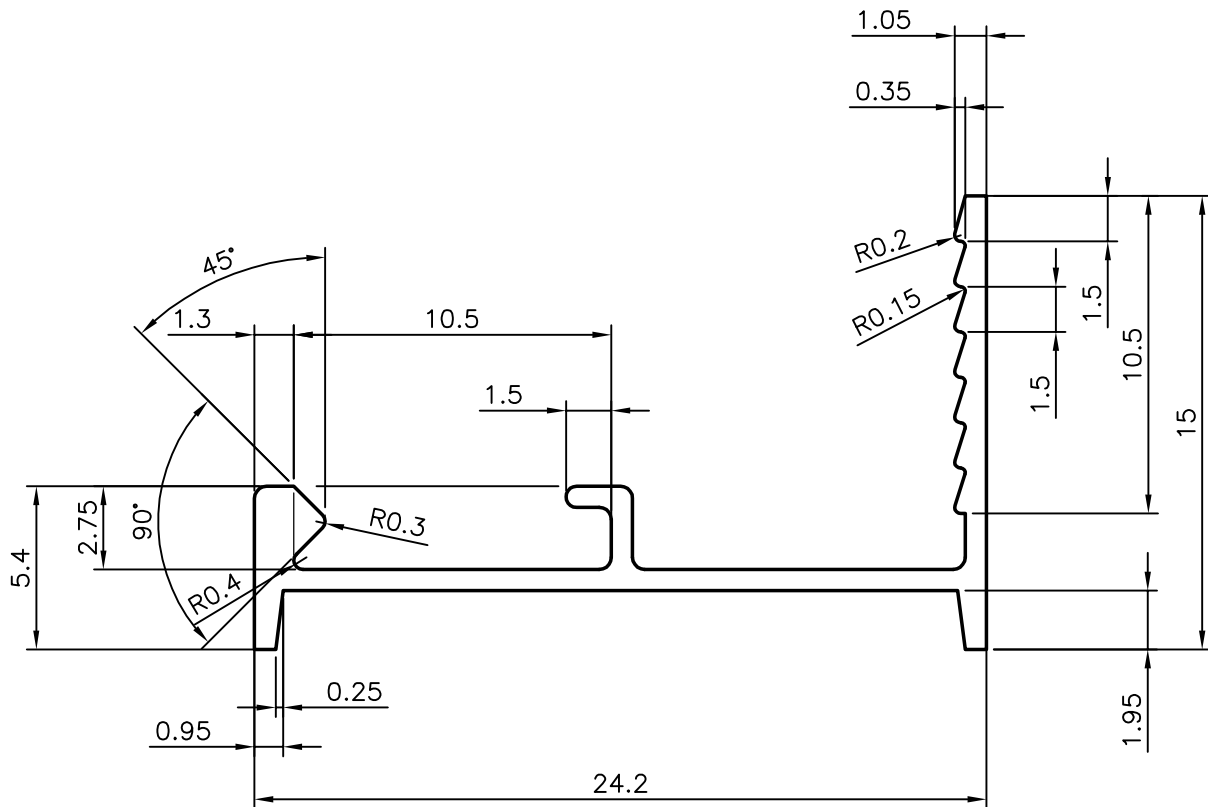
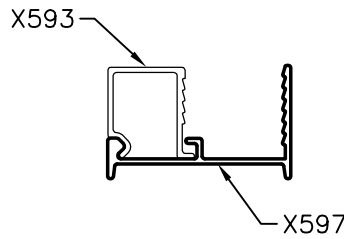
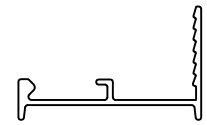

GENERAL WALL THICKNESS 0.70 mm (TYP)



SYMBOL OF QUALITY  
AN ISO 9001 COMPANY

**JINDAL ALUMINIUM LTD.**  
BANGALORE-560073 (INDIA)

	NAME	DATE
DRAWN	J.P.KAUSHIK	17-06-2006
CHECKED		
APPROVED		
SCALE		4:1
AREA mm <sup>2</sup>		38.629
PERIMETER mm.		97.026
WEIGHT kg/m		0.104
DRAWING No.	SECTION No.	
P-6501	-	
17633	17633	
X597	X597	

1. ALL DIMENSIONS ARE IN mm.
2. ROUND OFF ALL SHARP CORNERS WITH 0.40 mm.
3. TOLERANCES WILL BE AS PER BS:1474-1987 UNLESS OTHERWISE SPECIFIED

PARTY'S NAME	COMARK LANKA PVT LTD., SRILANKA
PARTY'S DRAWING No.	AS PER DRAWING (0083)
ALLOY & TEMPER	6063 T6
DESCRIPTION	MISC. SECTION